

Liquid Containing Rectangular Concrete Tank Design (ACI 318-14)

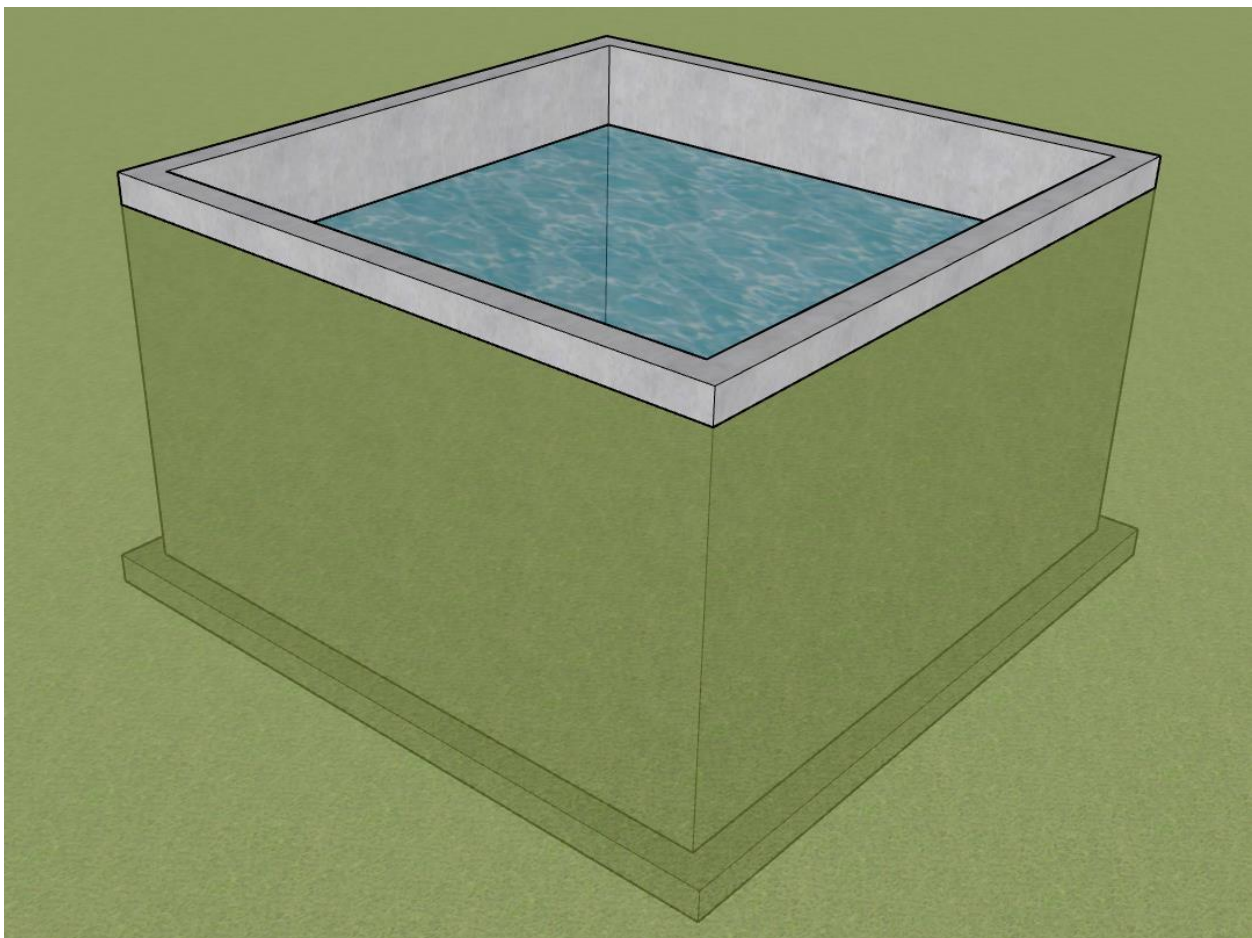

Liquid Containing Rectangular Concrete Tank Design (ACI 318-14)

Reinforced concrete tanks are used widely to collect and contain liquids from wastewater stations, process facilities, agricultural and environmental plants. In some cases the treatment to remove contaminants or solids also subjects concrete to additional requirements beyond structural design including the proper selection of materials, detailing, erection and construction practices to achieve maximum liquid tightness. Agricultural process byproduct requires a rigorous management agenda for controlling pollution from surface runoff that may be contaminated by chemicals in fertilizer, pesticides, animal slurry, crop residues, food, milk, blood, or irrigation water. In many cases, chemical and temperature exposure has to be considered in the analysis and design of reinforced concrete tanks. This case study focuses on the design of a wastewater collection rectangular tank (pit) using the engineering software programs [spWall](#) and [spMats](#). The tank under study is a 13 ft high partially buried open top fixed at the base to a 12" reinforced concrete base mat. The following figure and design data section will serve as input for detailed analysis and design. ACI 350 requirements are not evaluated in detail in this case study.

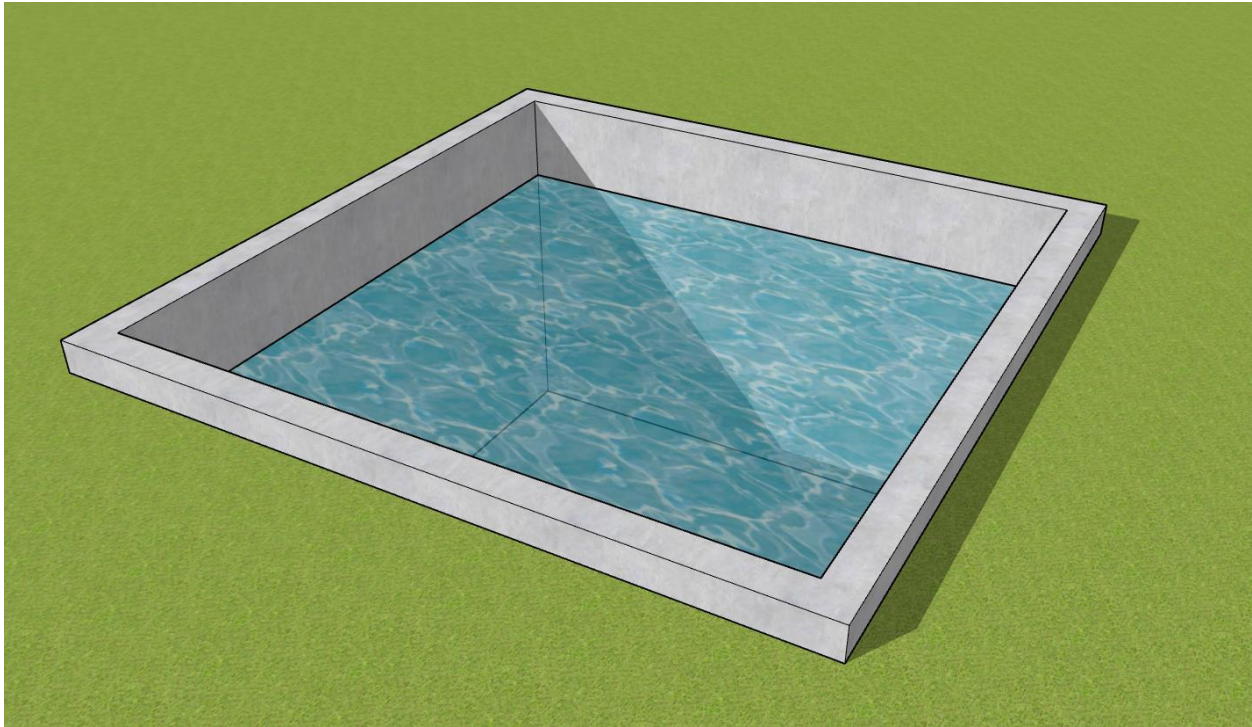
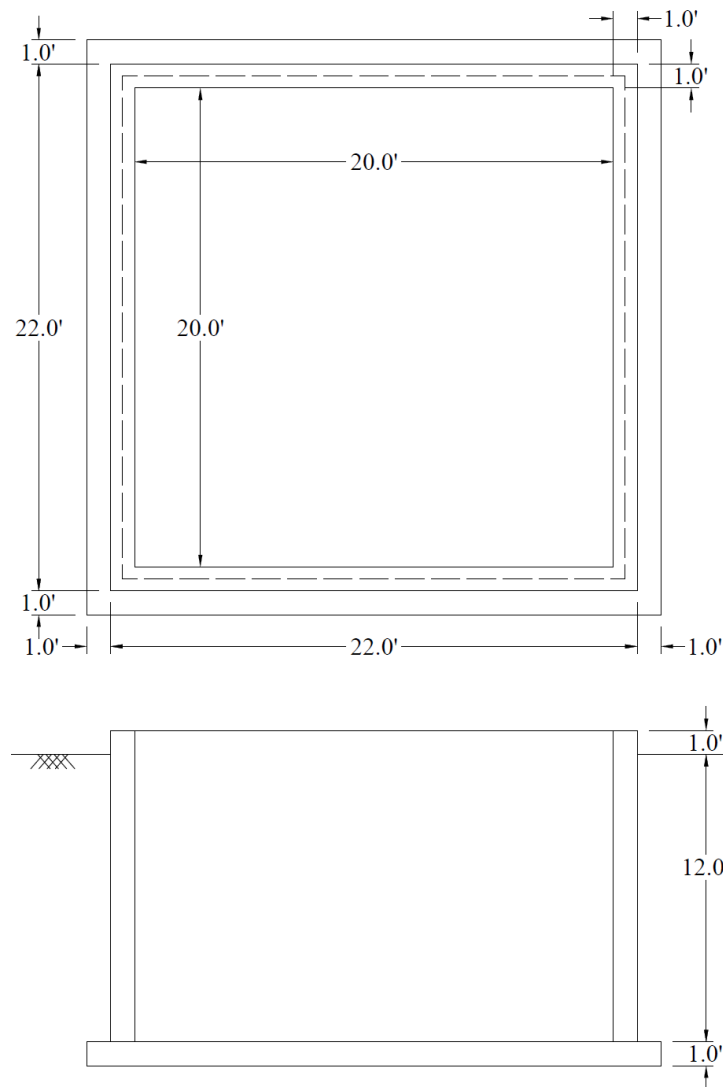

Figure 1 – Rectangular Concrete Tank Plan and Elevation

Contents

1. Wastewater Rectangular Concrete Tank Wall Analysis and Design – spWall Software	3
2. Tank Wall Model Input	4
3. Tank Wall Results Contours	10
4. Tank Wall Cross-Sectional Forces	12
5. Maximum Tank Wall Displacement	15
6. Tank Wall Cross-Sectional Forces at Fixed Base	16
7. Tank Wall Reactions at Fixed Base	17
8. Tank Wall Required Reinforcement.....	18
9. Tank Base Mat Analysis and Design – spMats Software.....	20
10. Tank Base Mat Model Input.....	20
11. Tank Base Mat Result Contours.....	27
12. Tank Base Mat Required Reinforcement	32
13. Soil Reactions / Pressure	34
14. Tank Base Mat Mesh Status	35
15. Tank Analysis Design Observation & Conclusions	36

Code

Building Code Requirements for Structural Concrete (ACI 318-14) and Commentary (ACI 318R-14)
Code Requirements for Environmental Engineering Concrete Structures and Commentary (ACI 350R-06)

Reference

- [spWall Engineering Software Program Manual v10.00, STRUCTUREPOINT, 2022](#)
- [spMats Engineering Software Program Manual v10.00, STRUCTUREPOINT, 2020](#)

Design Data

Tank Wall Materials

$f_c' = 4,000$ psi
 $f_y = 60,000$ psi

Tank Mat Foundation Materials

$f_c' = 4,000$ psi
 $f_y = 60,000$ psi

Tank Wall Dimensions

Width = 22 ft
Height = 13 ft
Thickness = 12 in.

Tanks Mat Foundation Dimensions

Width = 24 ft
Length = 24 ft
Thickness = 12 in.

Applied Tank Loads

In addition to wall and mat selfweights, the following figure shows all the loads applied to the tank:

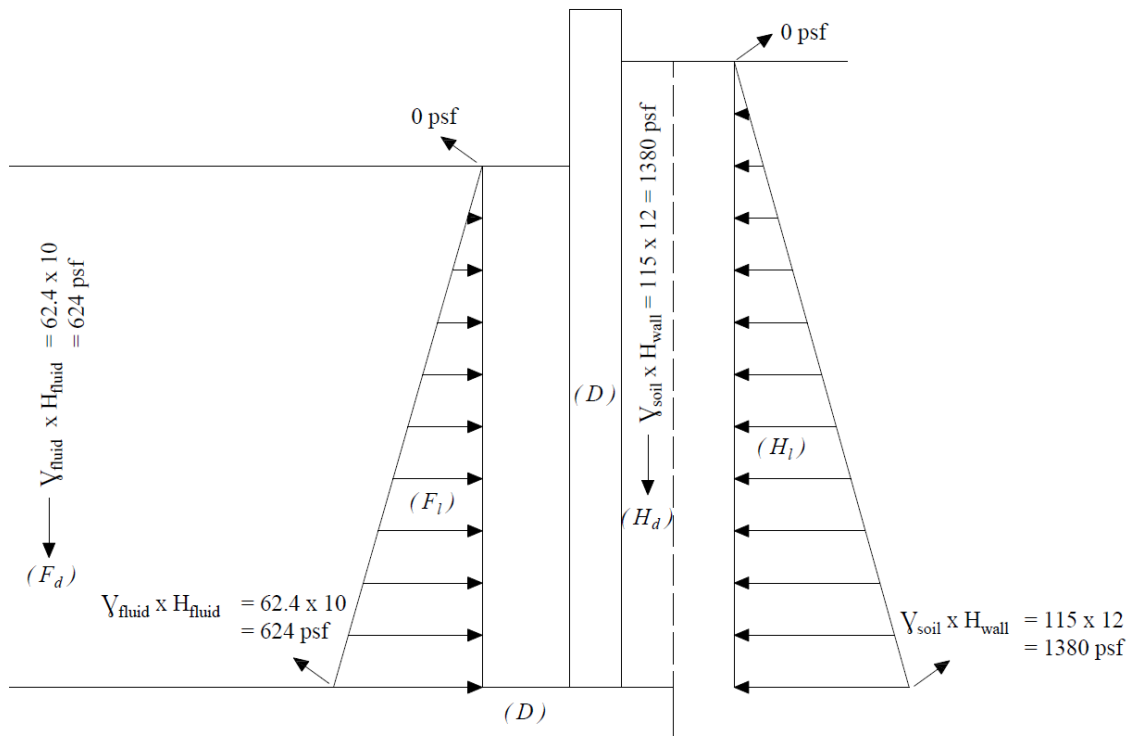
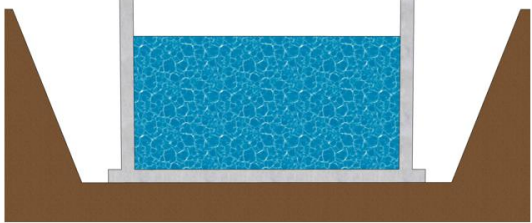
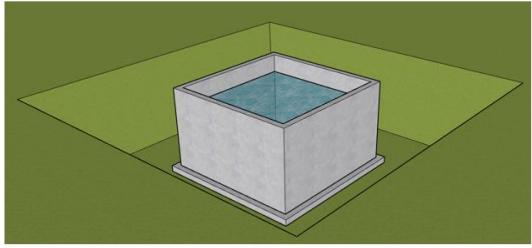
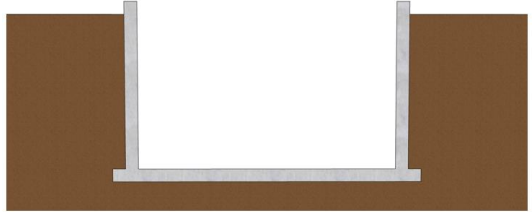
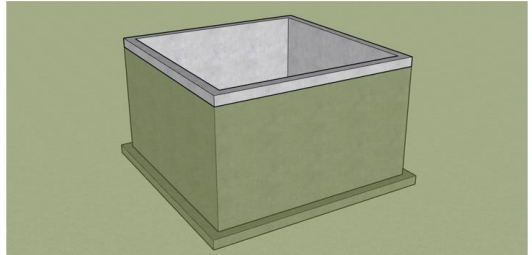
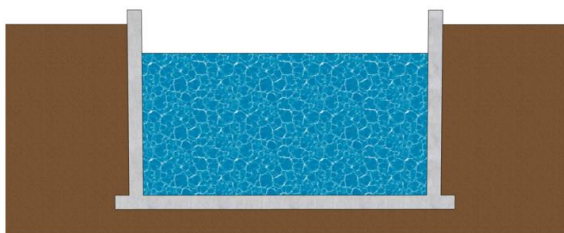
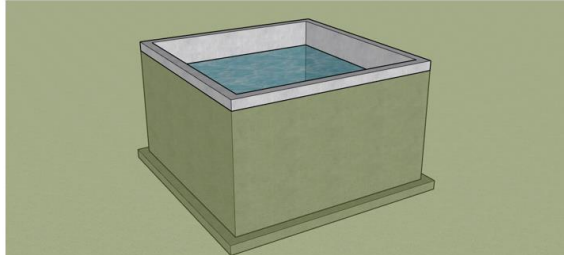

Figure 2 – Applied Loads (*l* and *d* indicated lateral and down respectively)

Load Combinations

Table 1 – Wastewater Tank Ultimate Load Combination	
<p><u>Test Phase – Tank full without backfill</u></p> <p>Test₁ = $1.4 \times (D + F_d) + 0.9 \times F_l$</p> <p>Test₂ = $0.9 \times (D + F_d) + 1.6 \times F_l$</p> <p>Test₃ = $1.2 \times (D + F_d) + 1.6 \times F_l$</p>	 
<p><u>Maintenance Phase – Tank empty with backfill</u></p> <p>Maintenance₁ = $0.9 \times (D + H_d) + 1.6 \times H_l$</p> <p>Maintenance₂ = $1.2 \times (D + H_d) + 1.6 \times H_l$</p>	 
<p><u>Operation Phase – Tank full with backfill</u></p> <p>Operation₁ = $1.2 \times (D + F_d) + 0.9 \times H_d + 1.6 \times F_l + 0.9 \times H_l$</p> <p>Operation₂ = $1.2 \times (D + H_d) + 0.9 \times F_d + 1.6 \times H_l + 0.9 \times F_l$</p>	 

1. Wastewater Rectangular Concrete Tank Wall Analysis and Design – [spWall](#) Software

[spWall](#) is a program for the analysis and design of reinforced concrete shear walls, tilt-up walls, precast walls, retaining walls, tank walls and Insulated Concrete Form (ICF) walls. It uses a graphical interface that enables the user to easily generate complex wall models. Graphical user interface is provided for:

- Wall geometry (including any number of openings and stiffeners)
- Material properties including cracking coefficients
- Wall loads (point, line, and area)
- Support conditions (including translational and rotational spring supports)

[spWall](#) uses the Finite Element Method for the structural modeling, analysis, and design of slender and non-slender reinforced concrete walls subject to static loading conditions. The wall is idealized as a mesh of rectangular plate elements and straight-line stiffener elements. Walls of irregular geometry are idealized to conform to geometry with rectangular boundaries. Plate and stiffener properties can vary from one element to another but are assumed by the program to be uniform within each element.

Six degrees of freedom exist at each node: three translations and three rotations relating to the three Cartesian axes. An external load can exist in the direction of each of the degrees of freedom. Sufficient number of nodal degrees of freedom should be restrained in order to achieve stability of the model. The program assembles the global stiffness matrix and load vectors for the finite element model. Then, it solves the equilibrium equations to obtain deflections and rotations at each node. Finally, the program calculates the internal forces and internal moments in each element. At the user's option, the program can perform second order analysis. In this case, the program takes into account the effect of in-plane forces on the out-of-plane deflection with any number of openings and stiffeners.

In [spWall](#), the required flexural reinforcement is computed based on the selected design standard (ACI 318-14 is used in this case study), and the user can specify one or two layers of wall reinforcement. In stiffeners and boundary elements, [spWall](#) calculates the required shear and torsion steel reinforcement. Wall concrete strength (in-plane and out-of-plane) is calculated for the applied loads and compared with the code permissible shear capacity.

For illustration purposes, the following figures provide a sample of the input modules and results obtained from an [spWall](#) model created for the rectangular wastewater tank walls in this case study.

2. Tank Wall Model Input

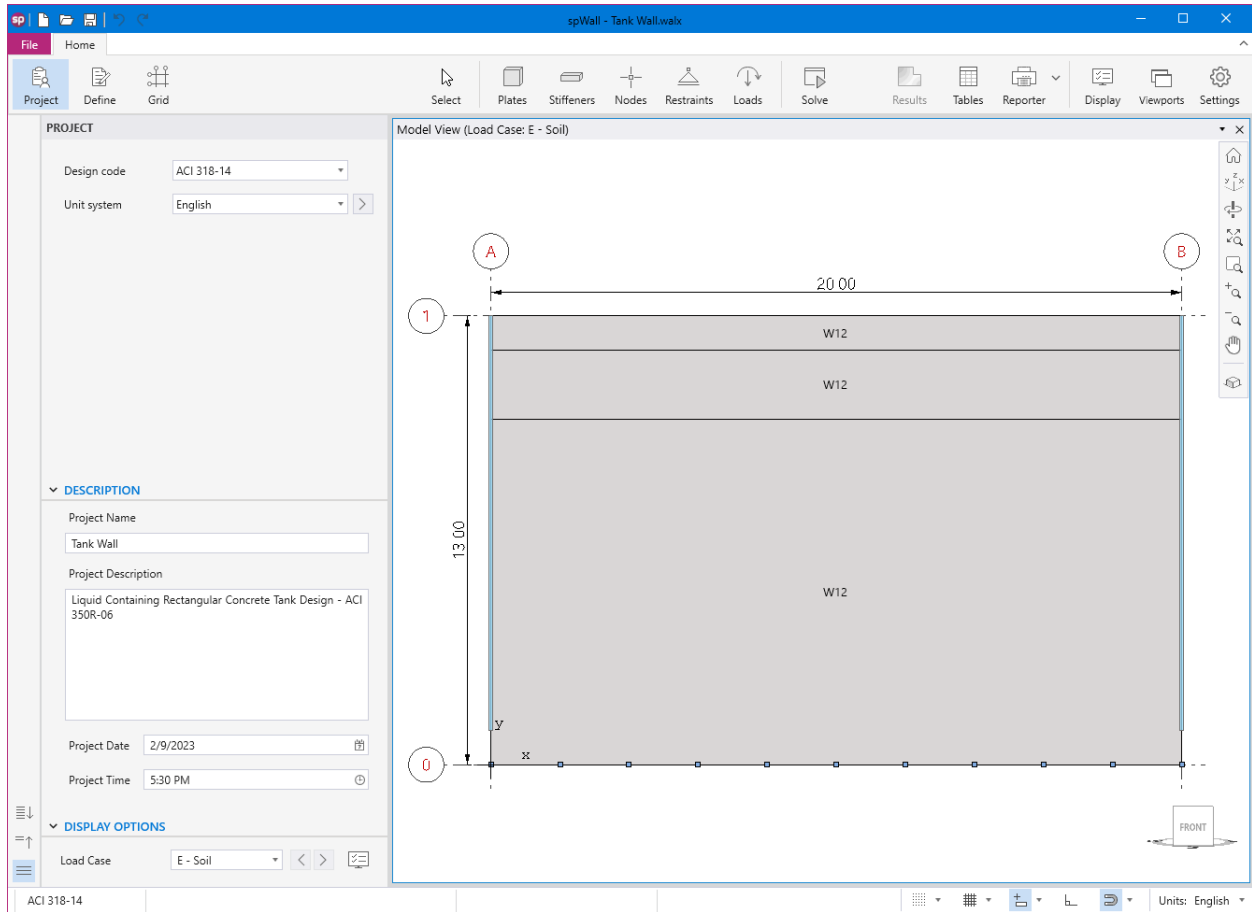

Figure 3 – spWall Interface

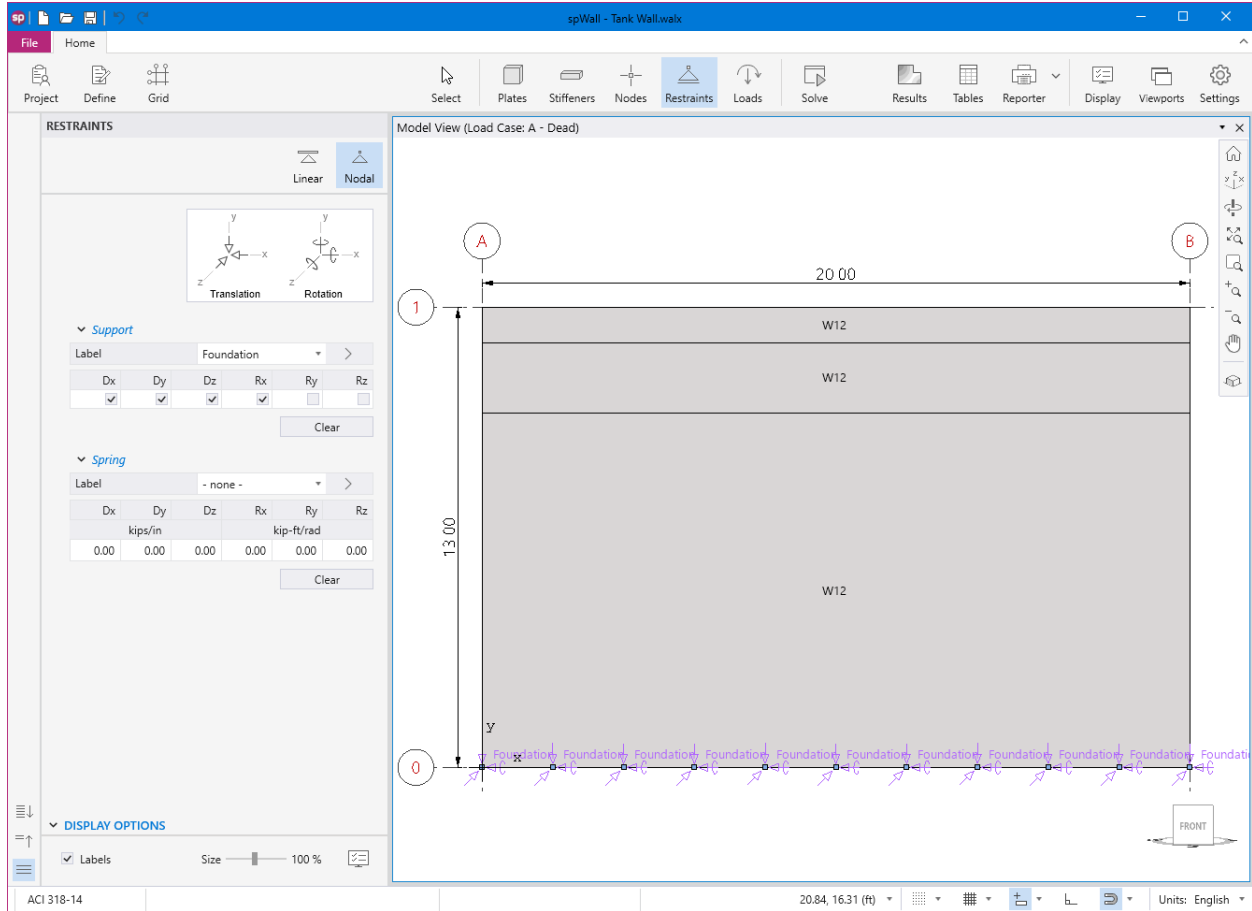

Figure 4 – Assigning Horizontal Wall Restraints (spWall)

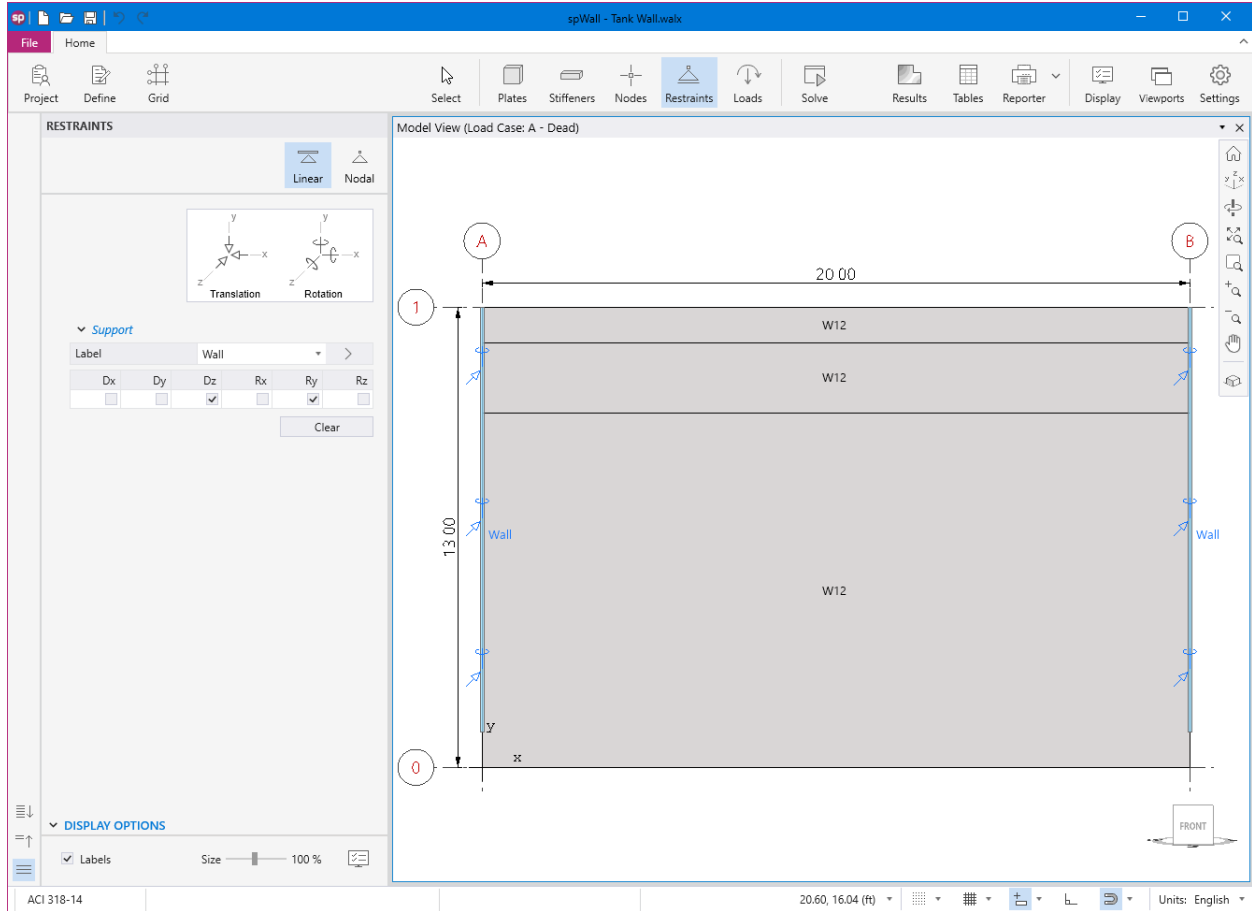

Figure 5 – Assigning Vertical Wall Restraints (spWall)

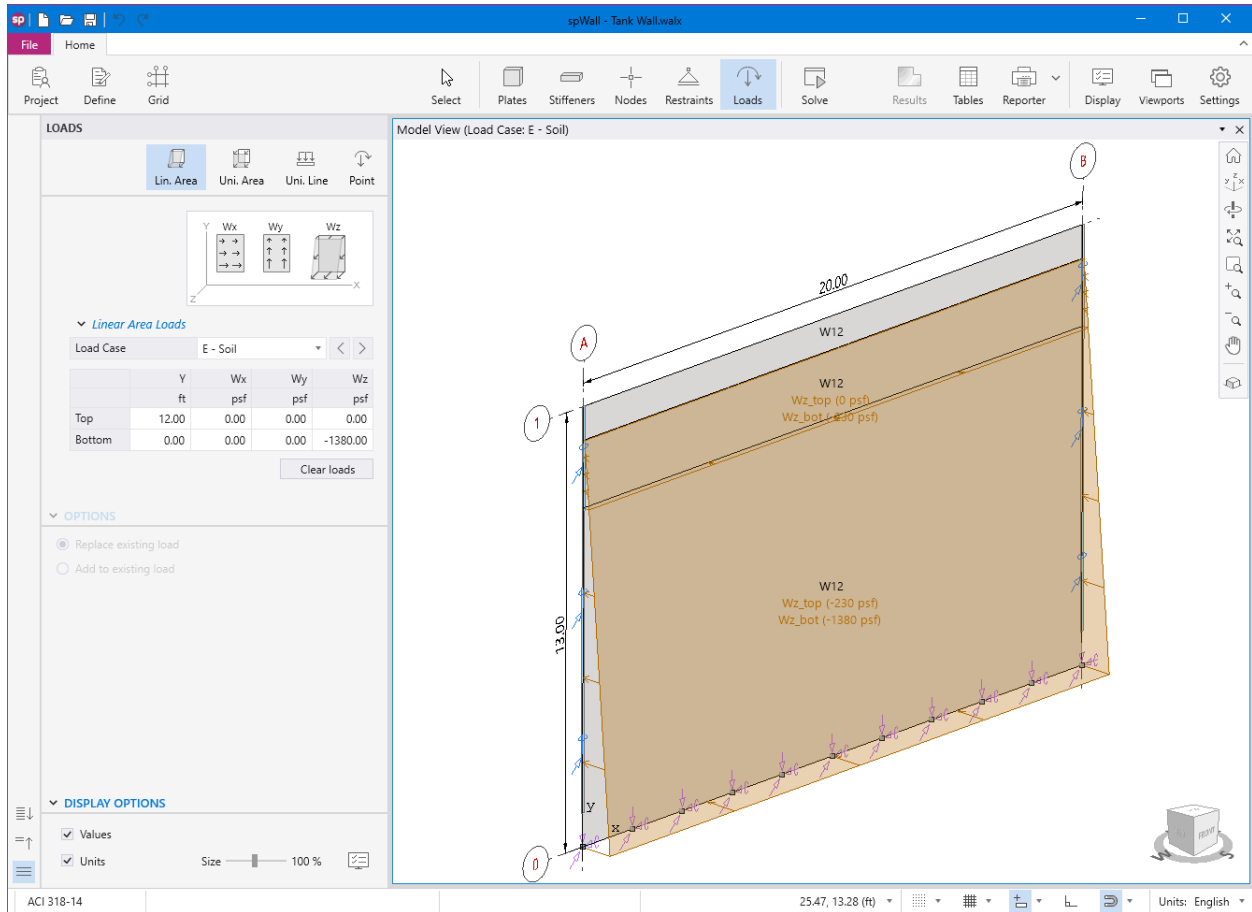

Figure 6 – Assigning Soil Loads (spWall)

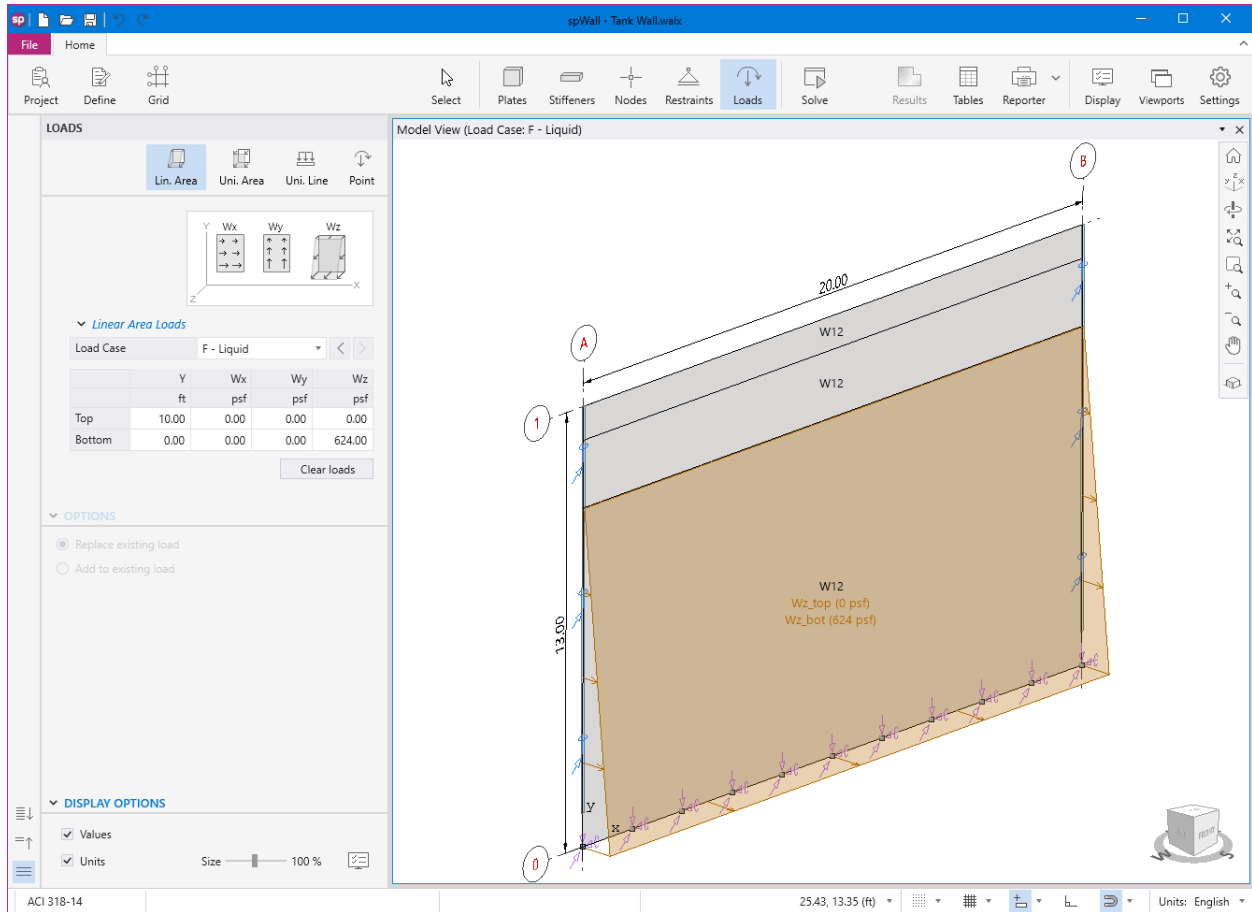

Figure 7 – Assigning Liquid Loads (spWall)

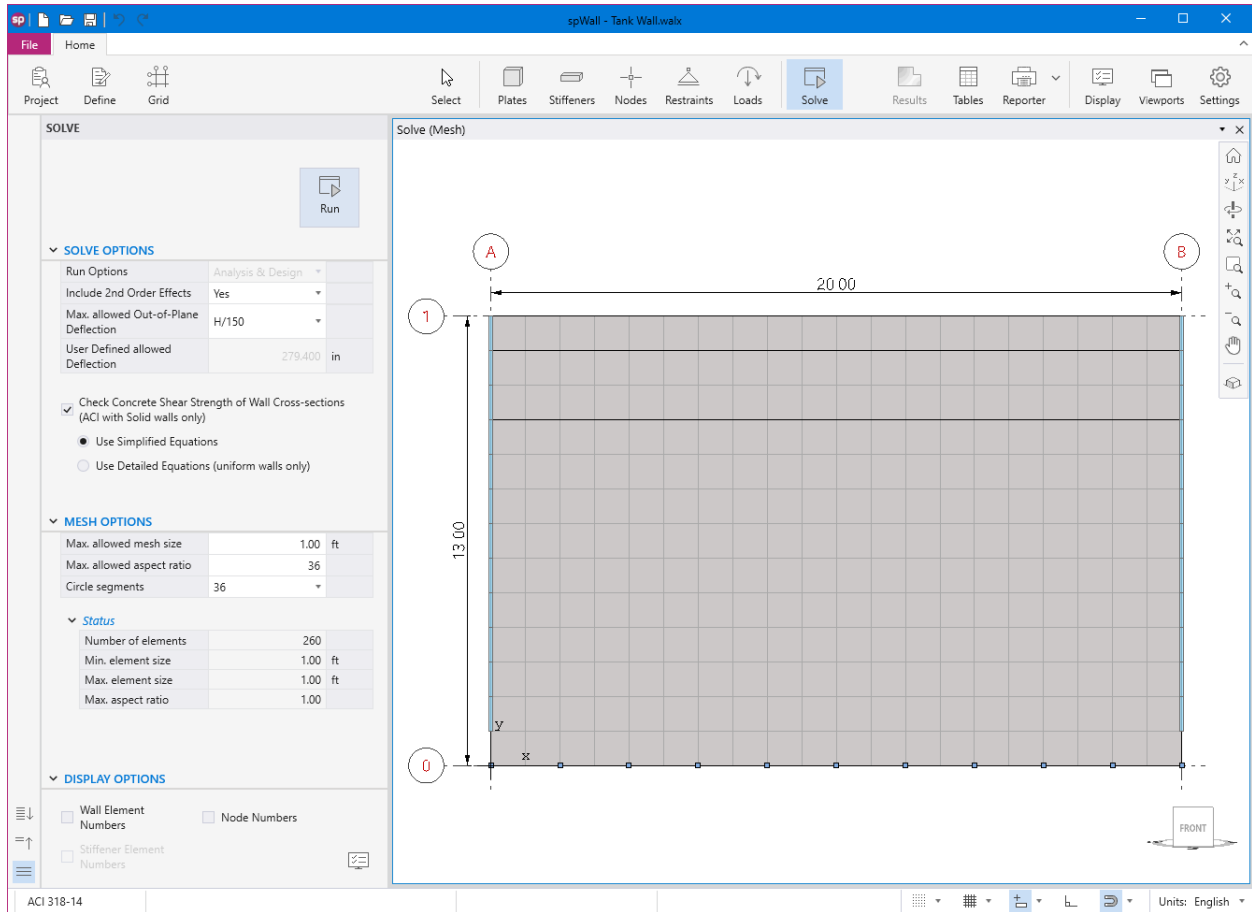

Figure 8 – Solve and Mesh Options (spWall)

3. Tank Wall Results Contours

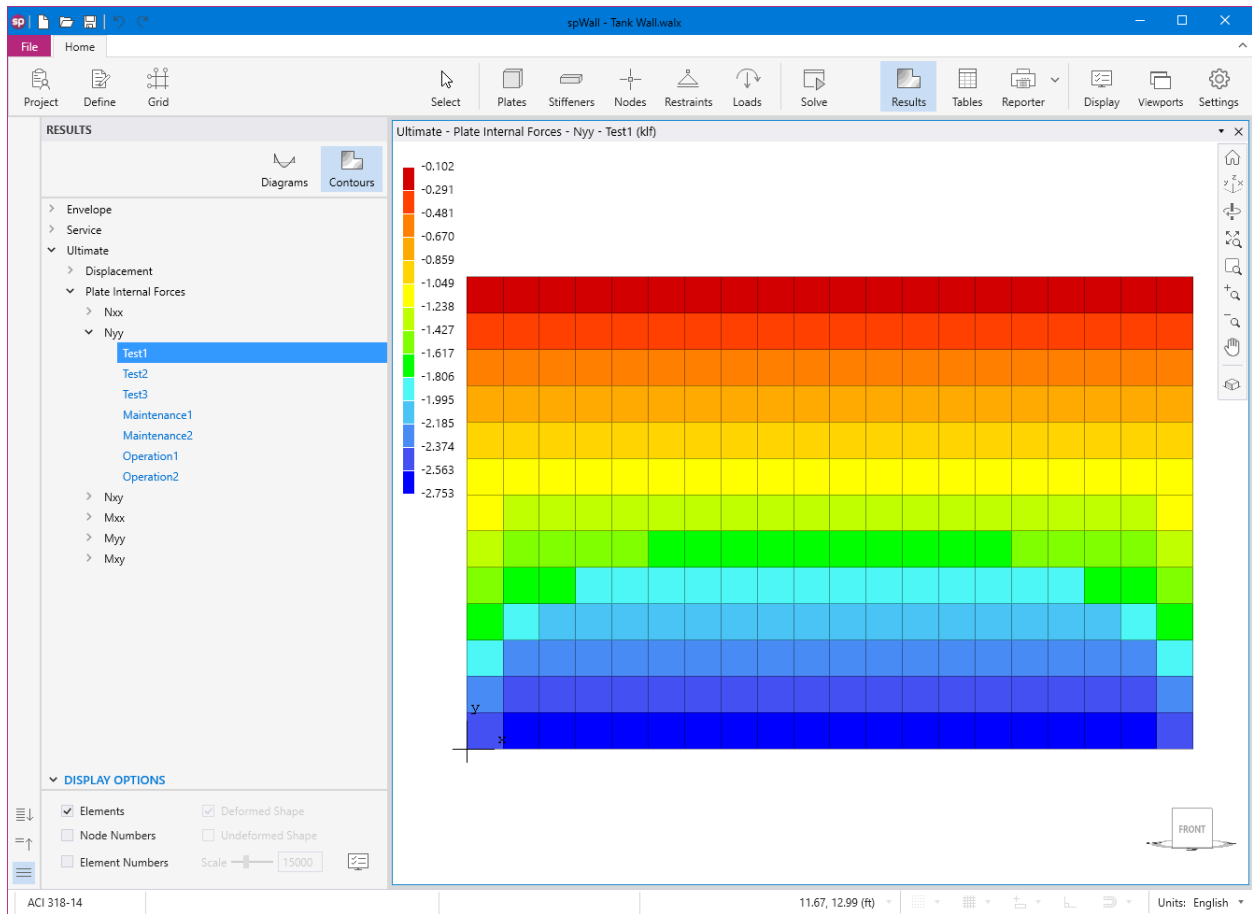

Figure 9 – Factored Axial Forces Contour Normal to Tank Wall Panel Cross-Section (spWall)

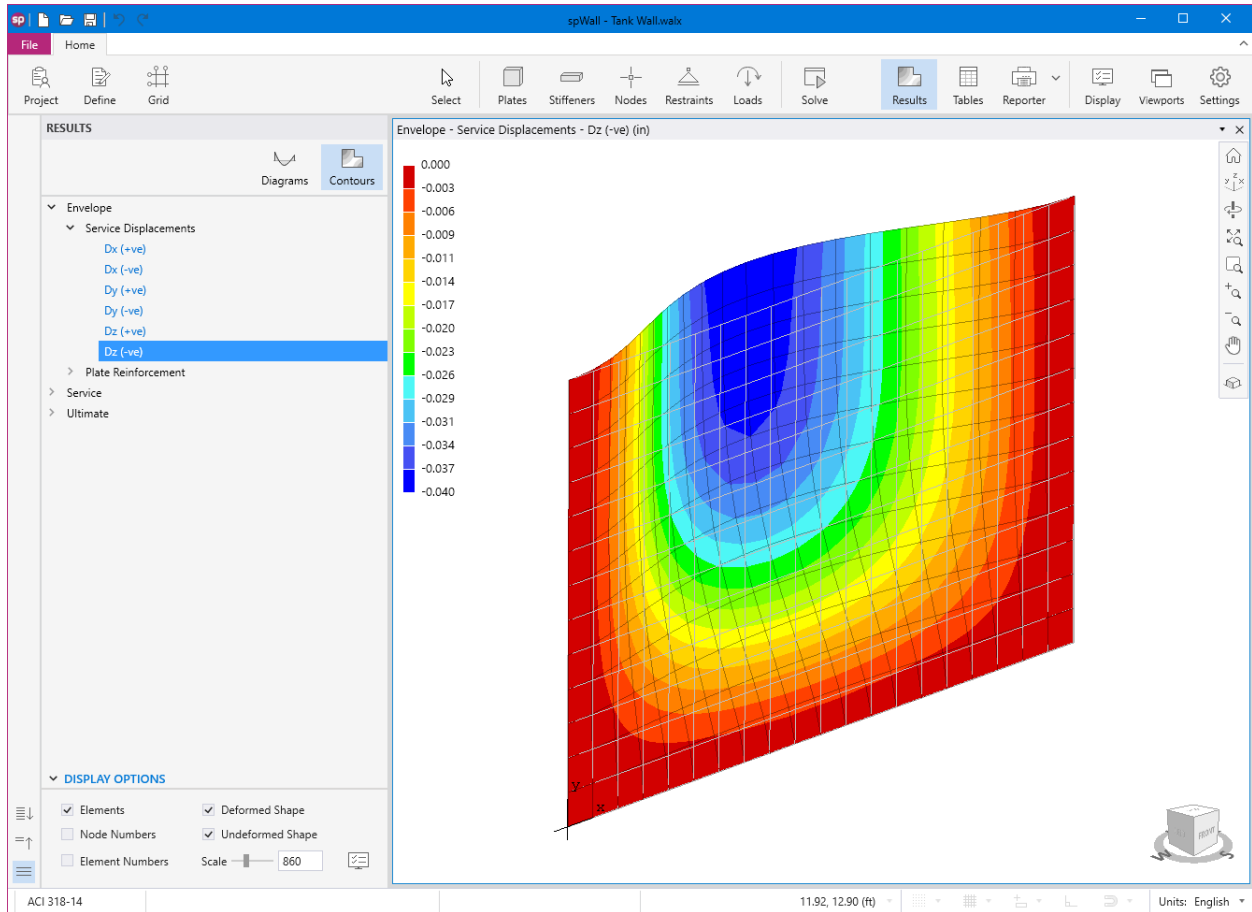

Figure 10 – Tank Wall Lateral Displacement Contour (Out-of-Plane) (spWall)

4. Tank Wall Cross-Sectional Forces

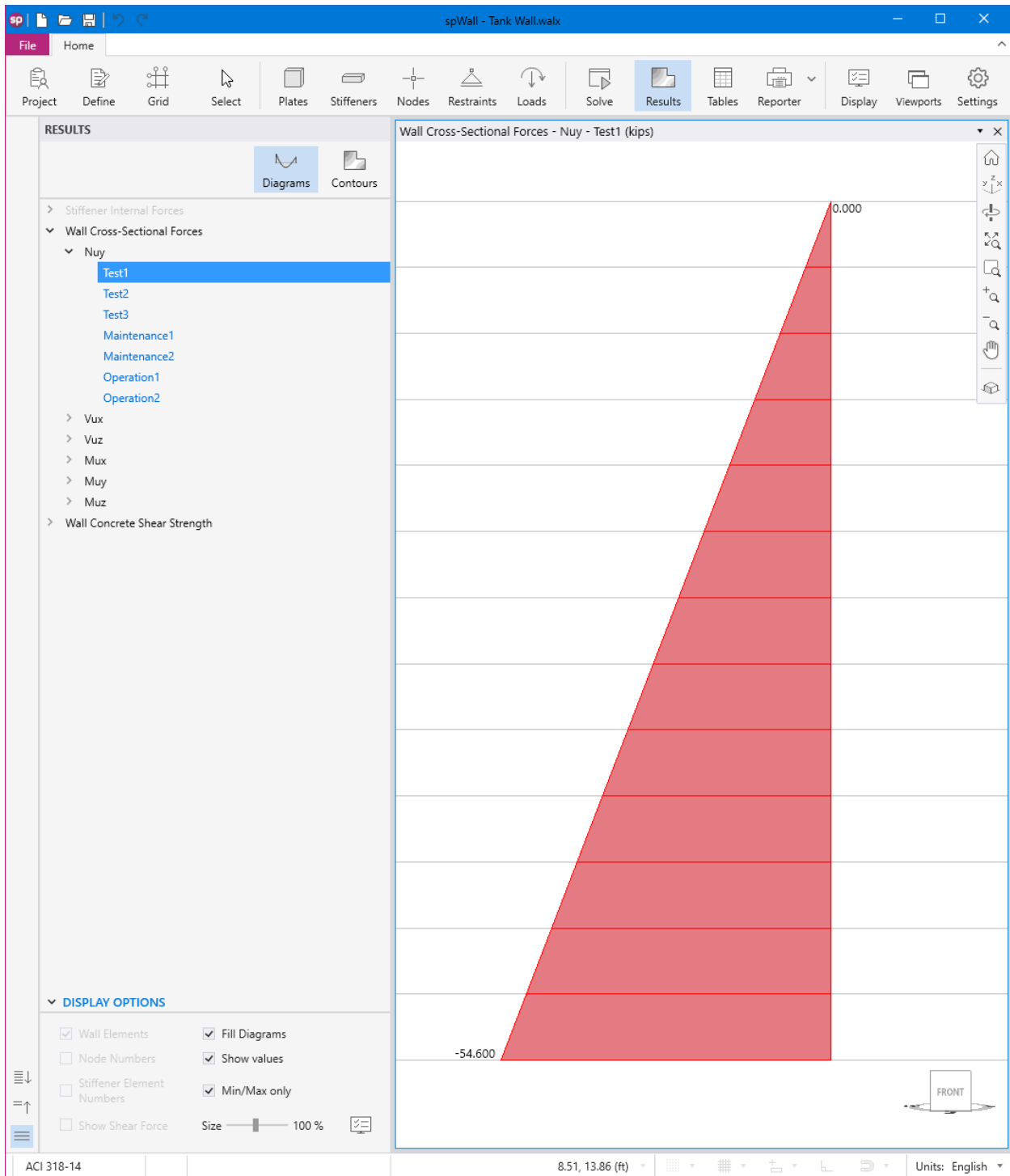

Figure 11 – Tank Wall Axial Load Diagram (spWall)

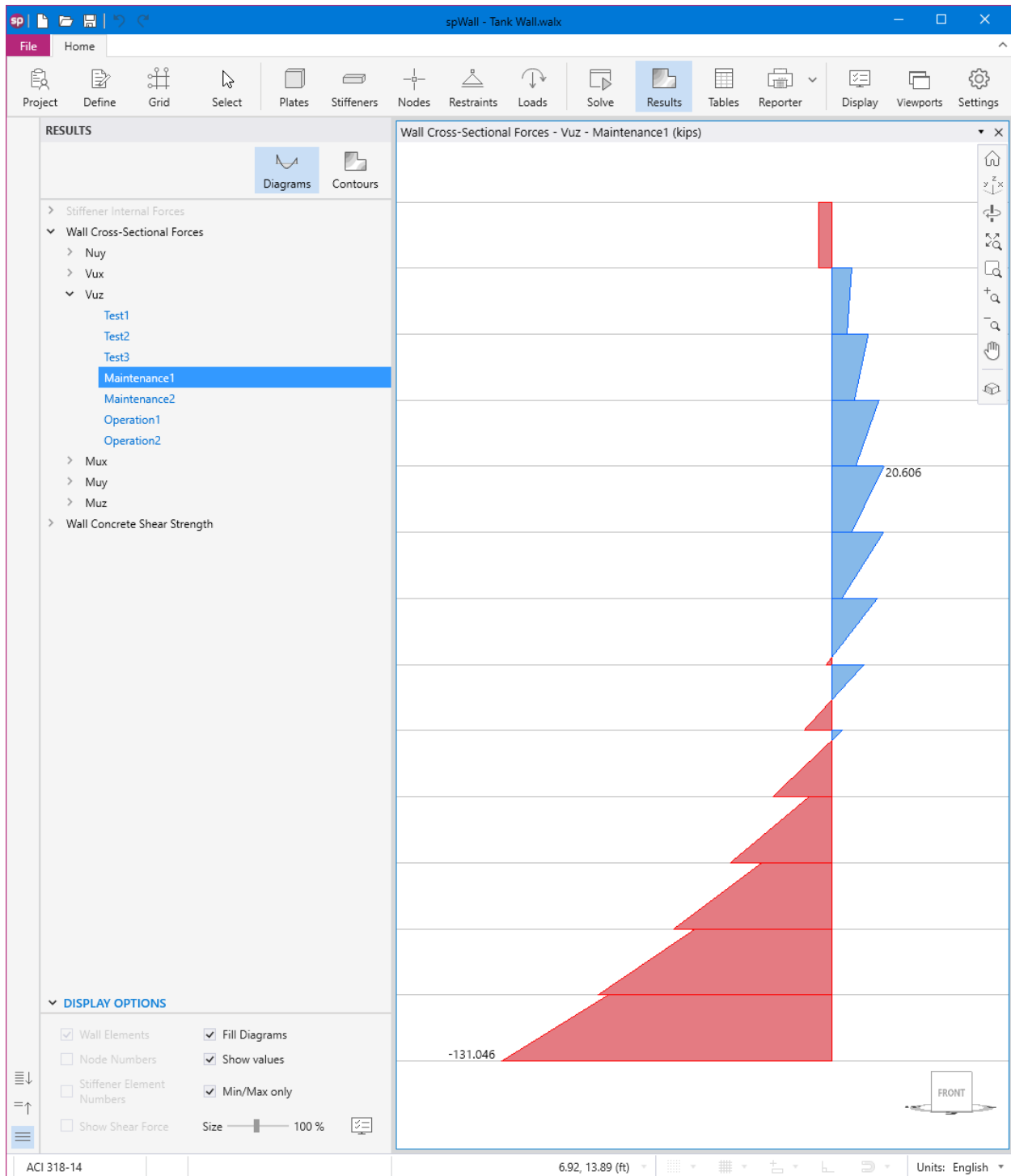

Figure 12 – Tank Wall Out-of-plane Shear Diagram (spWall)

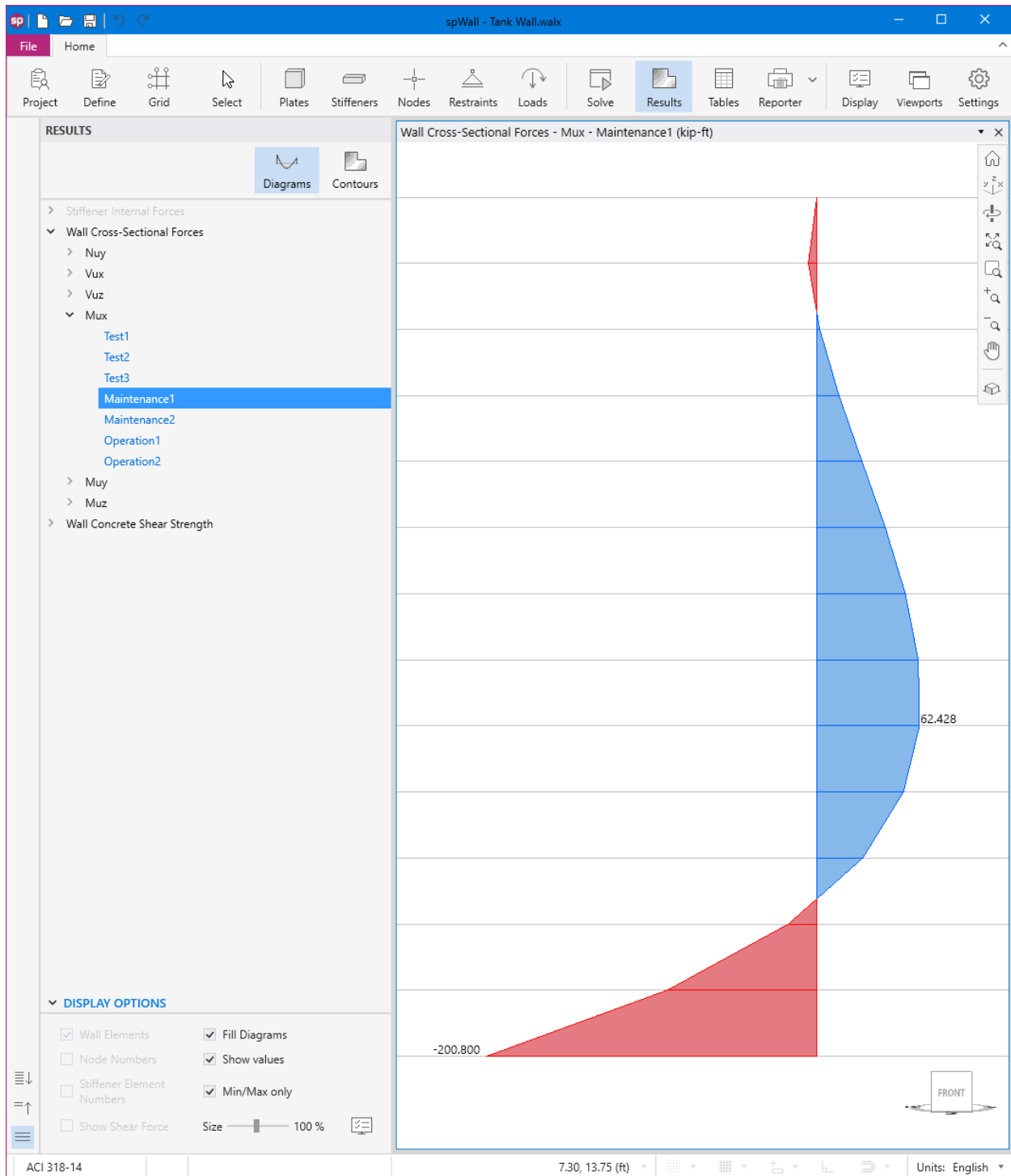

Figure 13 – Tank Wall Moment Diagram (spWall)

5. Maximum Tank Wall Displacement

1. Results

1.1. Service

1.1.1. Nodal Displacements

1.1.1.1. S2

Coordinate System: Global

Node	Dx in	Dy in	Dz in
169	0.000	0.000	0.000
170	0.000	0.000	0.000
171	0.000	0.000	0.002
172	0.000	0.000	0.003
173	0.000	0.000	0.005
174	0.000	0.000	0.007
175	0.000	0.000	0.008
176	0.000	0.000	0.010
177	0.000	0.000	0.011
178	0.000	0.000	0.011
179	0.000	0.000	0.011
180	0.000	0.000	0.011
181	0.000	0.000	0.011
182	0.000	0.000	0.010
183	0.000	0.000	0.008
184	0.000	0.000	0.007
185	0.000	0.000	0.005
186	0.000	0.000	0.003
187	0.000	0.000	0.002
188	0.000	0.000	0.000
189	0.000	0.000	0.000

Figure 14 – Displacement at Critical Section (Service Combinations) (spWall)

1.2. Ultimate

1.2.1. Nodal Displacements

1.2.1.1. Maintenance1

Coordinate System: Global

Node	Dx in	Dy in	Dz in
274	0.000	0.000	0.000
275	0.000	0.000	-0.007
276	0.000	0.000	-0.026
277	0.000	0.000	-0.055
278	0.000	0.000	-0.089
279	0.000	0.000	-0.124
280	0.000	0.000	-0.156
281	0.000	0.000	-0.185
282	0.000	0.000	-0.206
283	0.000	0.000	-0.220
284	0.000	0.000	-0.224
285	0.000	0.000	-0.220
286	0.000	0.000	-0.206
287	0.000	0.000	-0.185
288	0.000	0.000	-0.156
289	0.000	0.000	-0.124
290	0.000	0.000	-0.089
291	0.000	0.000	-0.055
292	0.000	0.000	-0.026
293	0.000	0.000	-0.007
294	0.000	0.000	0.000

Figure 15 – Displacement at Critical Section (Ultimate Combinations) (spWall)

6. Tank Wall Cross-Sectional Forces at Fixed Base

1.2.2. Wall Cross-Sectional Forces

1.2.2.1. Maintenance1

Coordinate System: Global

(+) Horizontal cross-section above Y-coordinate

(-) Horizontal cross-section below Y-coordinate

No.	Wall Crossection		In-Plane Forces			Out-Of-Plane Forces		
	Y coordinate ft	X-Centroid ft	Vux kips	Nuy kips	Muz kip-ft	Vuz kips	Mux kip-ft	Muy kip-ft
1+	0.00	10.00	0.00	-35.10	0.00	-131.05	-200.80	0.00

Figure 16 – Cross-Sectional Forces (spWall)

7. Tank Wall Reactions at Fixed Base

The following wall reactions will serve as the input to the mat foundation model and will be used as the part of the primary load cases in [spMats](#). The reactions along the vertical wall edge have an equal and opposite force from the opposite tank wall. A small in plane shear is generated causing a negligible axial stress in the walls.

1.1.2. Reactions

1.1.2.1. Self-Weight Wall R...

Coordinate System: Global

Node	Fx kips	Fy kips	Fz kips	Mx kip-ft	My kip-ft	Mz kip-ft
1	1.01	1.91	0.00	0.00	0.00	0.00
3	-0.13	4.03	0.00	0.00	0.00	0.00
5	0.11	3.89	0.00	0.00	0.00	0.00
7	0.10	3.87	0.00	0.00	0.00	0.00
9	0.05	3.87	0.00	0.00	0.00	0.00
11	0.00	3.87	0.00	0.00	0.00	0.00
13	-0.05	3.87	0.00	0.00	0.00	0.00
15	-0.10	3.87	0.00	0.00	0.00	0.00
17	-0.11	3.89	0.00	0.00	0.00	0.00
19	0.13	4.03	0.00	0.00	0.00	0.00
21	-1.01	1.91	0.00	0.00	0.00	0.00

1.1.2.2. Liquid Wall Reactions

Coordinate System: Global

Node	Fx kips	Fy kips	Fz kips	Mx kip-ft	My kip-ft	Mz kip-ft
1	0.00	0.00	0.64	0.08	0.00	0.00
3	0.00	0.00	-1.37	-1.70	0.00	0.00
5	0.00	0.00	-3.74	-4.32	0.00	0.00
7	0.00	0.00	-4.70	-6.24	0.00	0.00
9	0.00	0.00	-5.19	-7.40	0.00	0.00
11	0.00	0.00	-5.33	-7.78	0.00	0.00
13	0.00	0.00	-5.19	-7.40	0.00	0.00
15	0.00	0.00	-4.70	-6.24	0.00	0.00
17	0.00	0.00	-3.74	-4.32	0.00	0.00
19	0.00	0.00	-1.37	-1.70	0.00	0.00
21	0.00	0.00	0.64	0.08	0.00	0.00

1.1.2.3. Soil Wall Reactions

Coordinate System: Global

Node	Fx kips	Fy kips	Fz kips	Mx kip-ft	My kip-ft	Mz kip-ft
1	0.00	0.00	-1.68	-0.19	0.00	0.00
3	0.00	0.00	2.64	4.20	0.00	0.00
5	0.00	0.00	8.77	11.26	0.00	0.00
7	0.00	0.00	11.52	16.73	0.00	0.00
9	0.00	0.00	12.99	20.12	0.00	0.00
11	0.00	0.00	13.42	21.25	0.00	0.00
13	0.00	0.00	12.99	20.12	0.00	0.00
15	0.00	0.00	11.52	16.73	0.00	0.00
17	0.00	0.00	8.77	11.26	0.00	0.00
19	0.00	0.00	2.64	4.20	0.00	0.00
21	0.00	0.00	-1.68	-0.19	0.00	0.00

Figure 17 – Tank Wall Reactions (Service Combinations) ([spWall](#))

8. Tank Wall Required Reinforcement

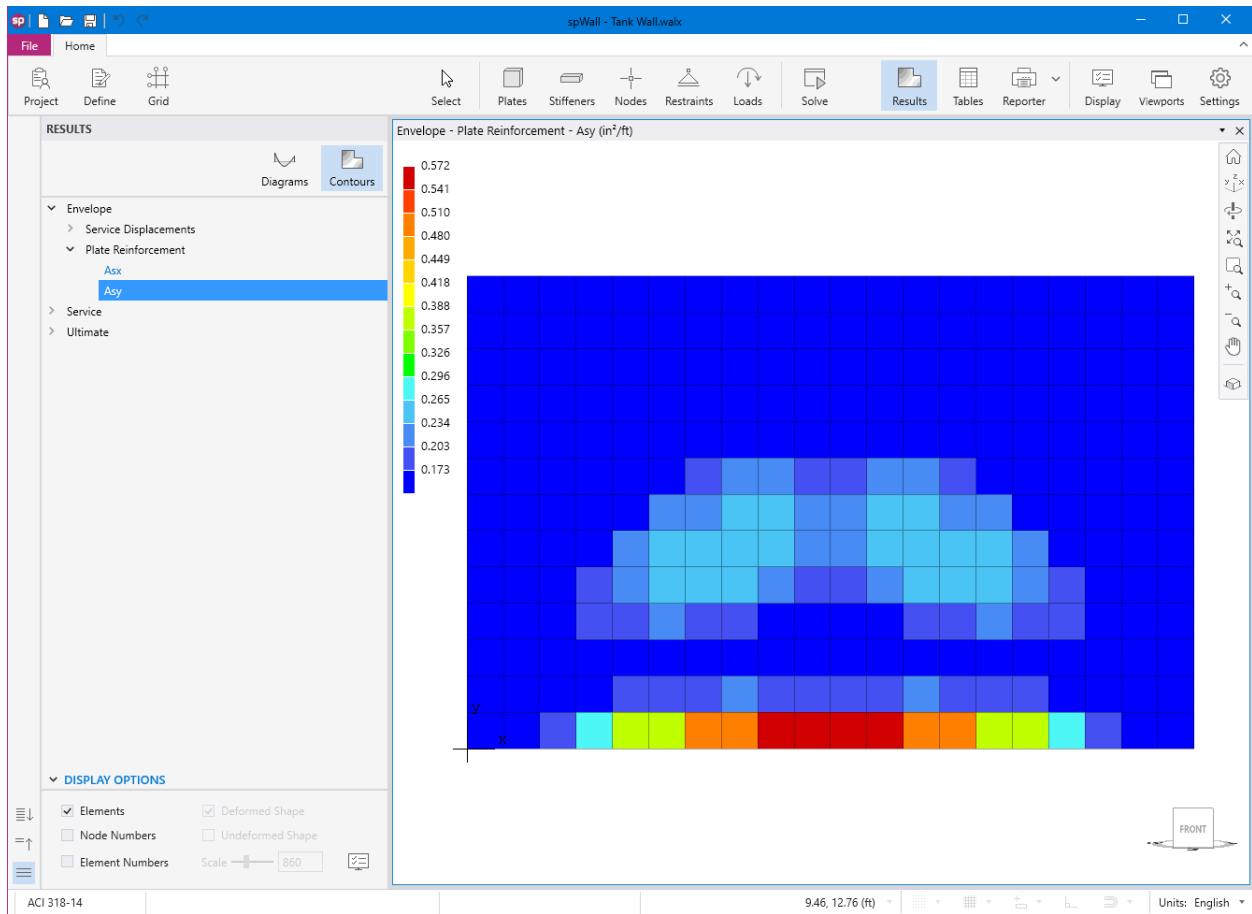

Figure 18 – Required Vertical Reinforcement (spWall)

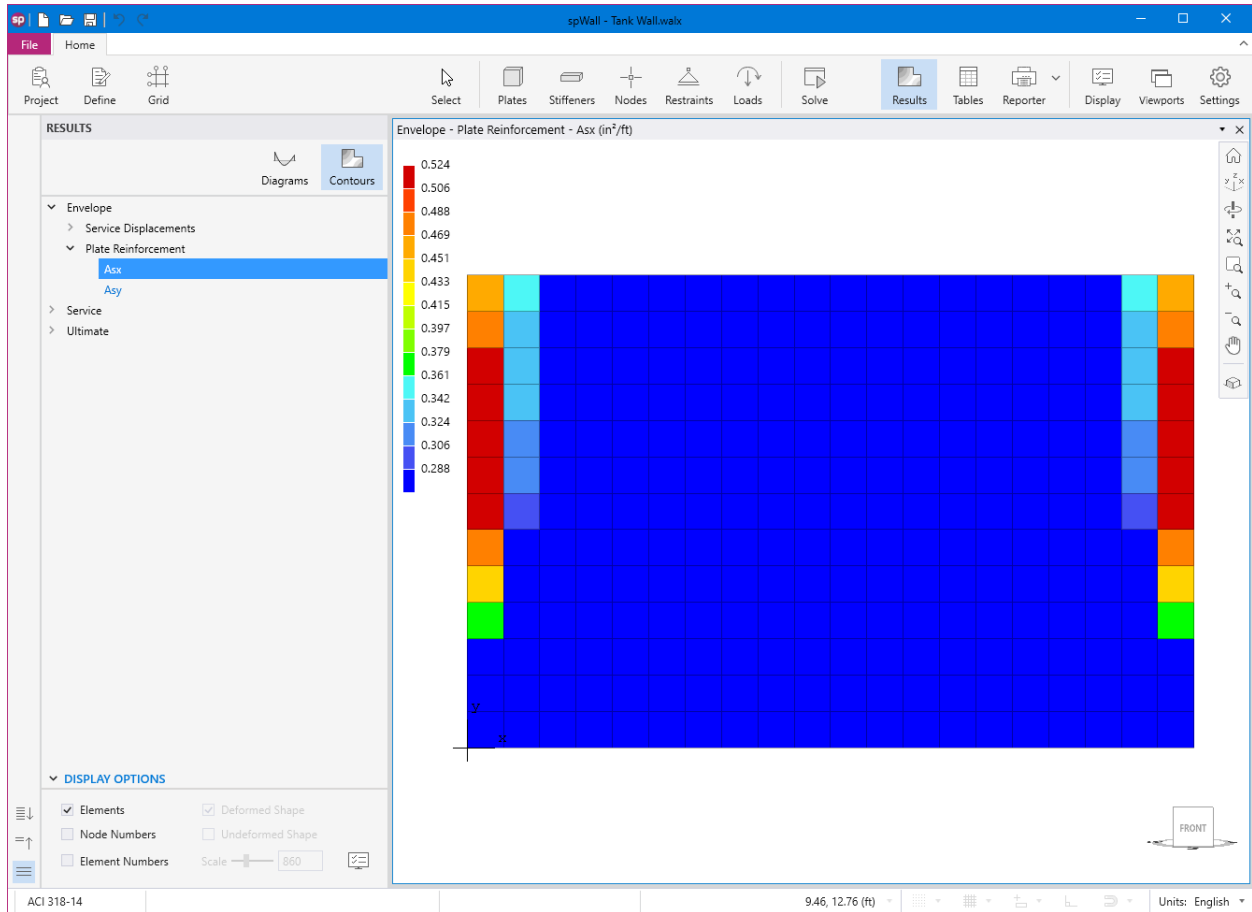

Figure 19 – Required Horizontal Reinforcement (spWall)

9. Tank Base Mat Analysis and Design – [spMats](#) Software

[spMats](#) uses the Finite Element Method for the structural modeling, analysis and design of reinforced concrete slab systems or mat foundations subject to static loading conditions.

The slab, mat, or footing is idealized as a mesh of rectangular elements interconnected at the corner nodes. The same mesh applies to the underlying soil with the soil stiffness concentrated at the nodes. Slabs of irregular geometry can be idealized to conform to geometry with rectangular boundaries. Even though slab and soil properties can vary between elements, they are assumed uniform within each element. Piles and/or supporting soil are modeled as springs connected to the nodes of the finite element model. Unlike for springs, however, punching shear check is performed around piles.

For illustration purposes, the following figures provide a sample of the input modules and results obtained from an [spMats](#) model created for the wastewater tank base mat in this case study.

10. Tank Base Mat Model Input

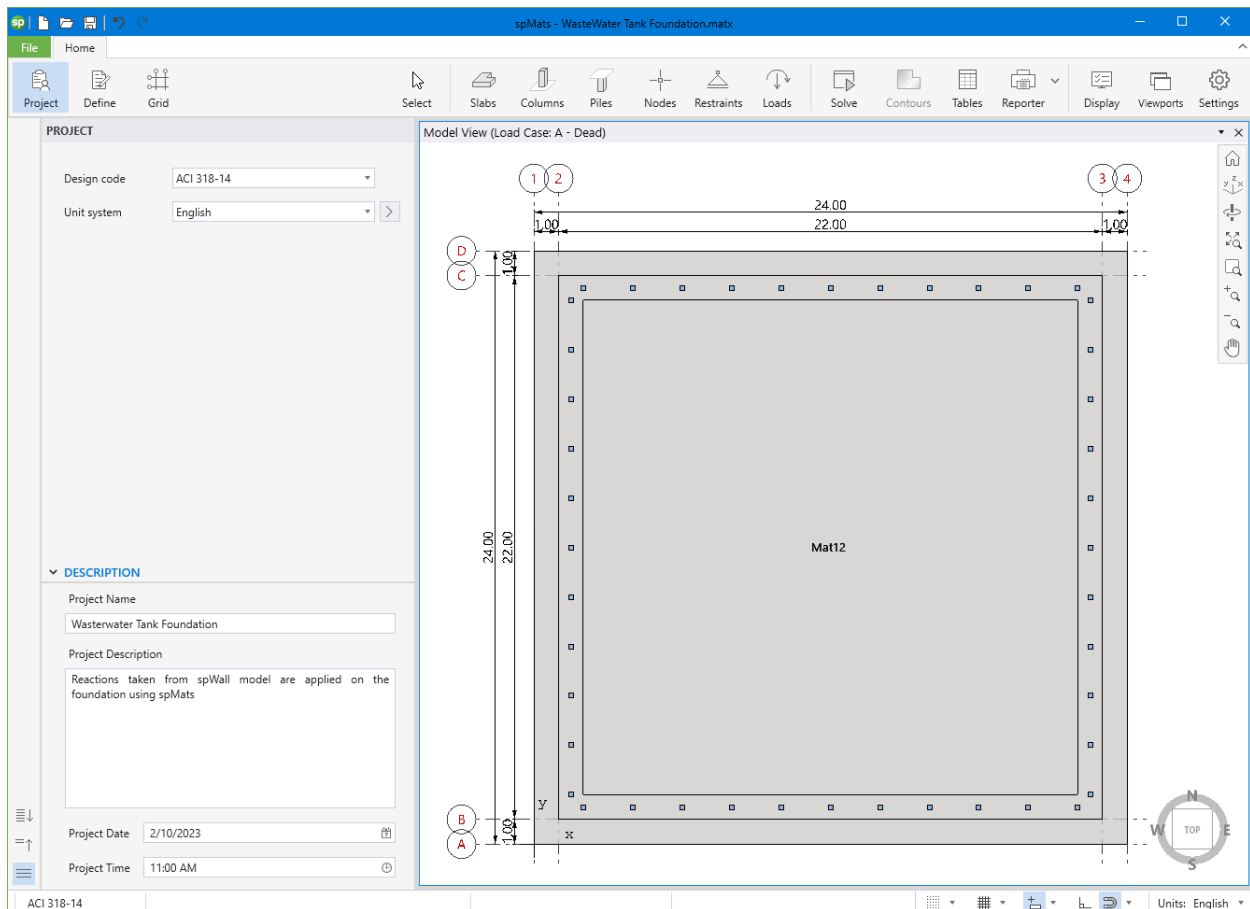

Figure 20 – [spMats](#) Interface

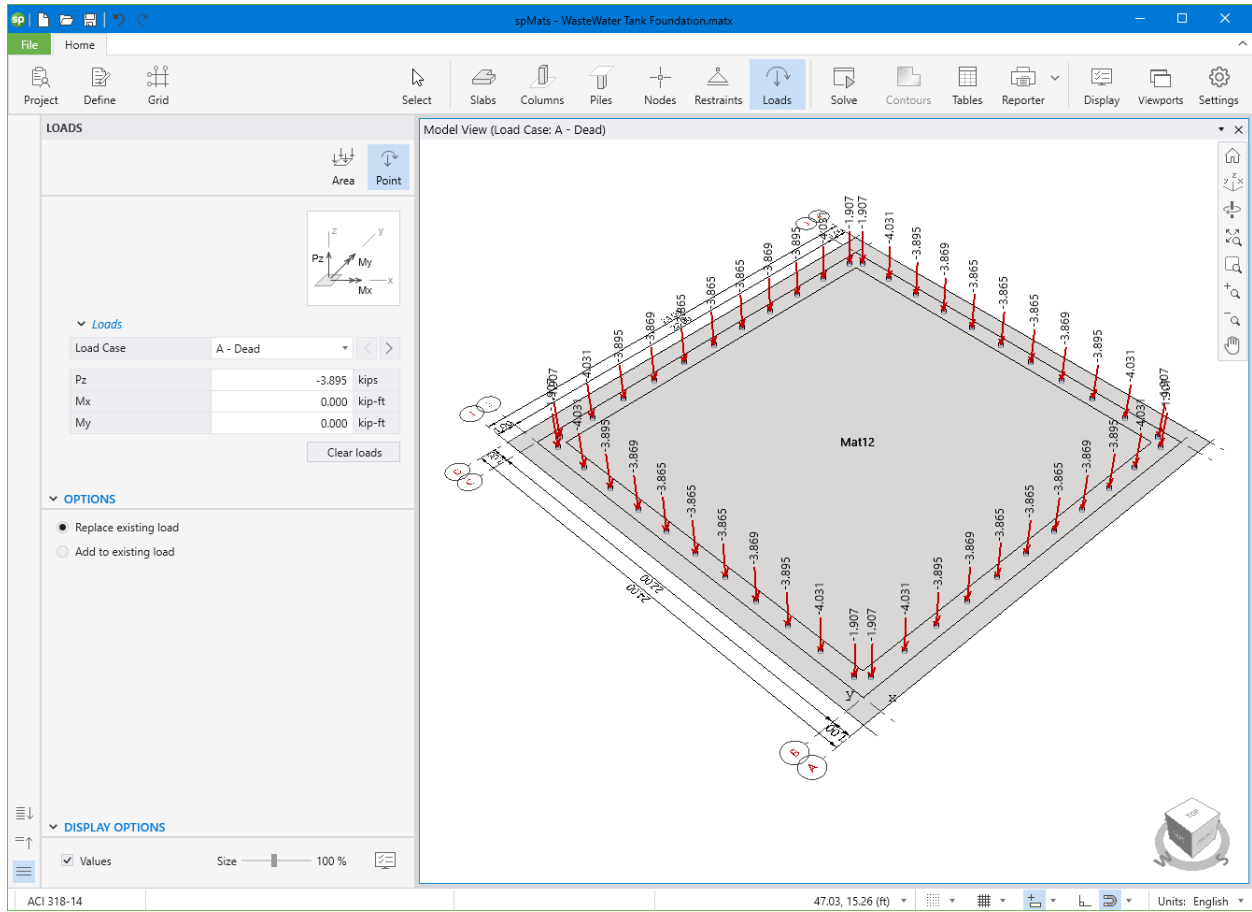

Figure 21 – Assigning Wall Self-Weight Reactions (spMats)

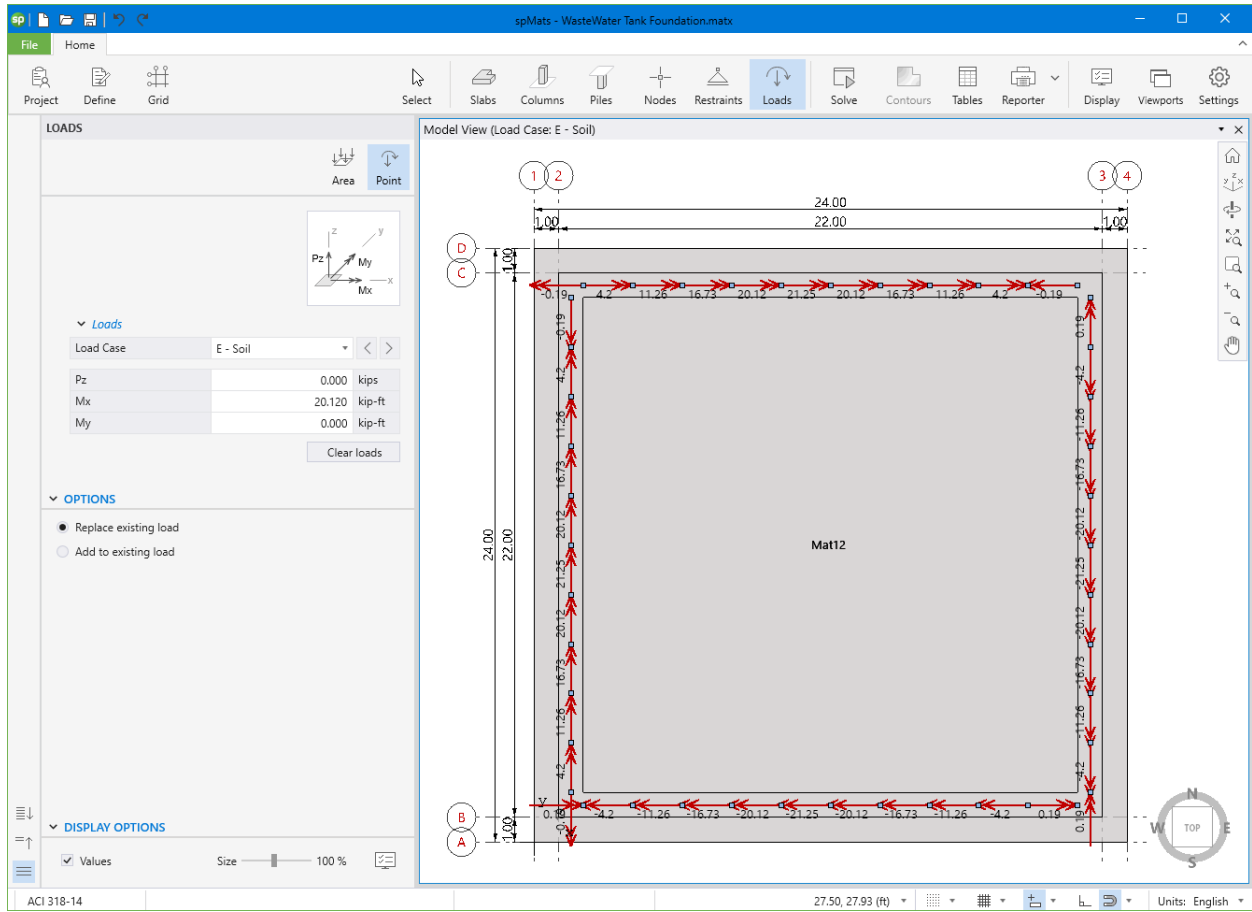

Figure 22 – Assigning Wall Soil Reactions (spMats)

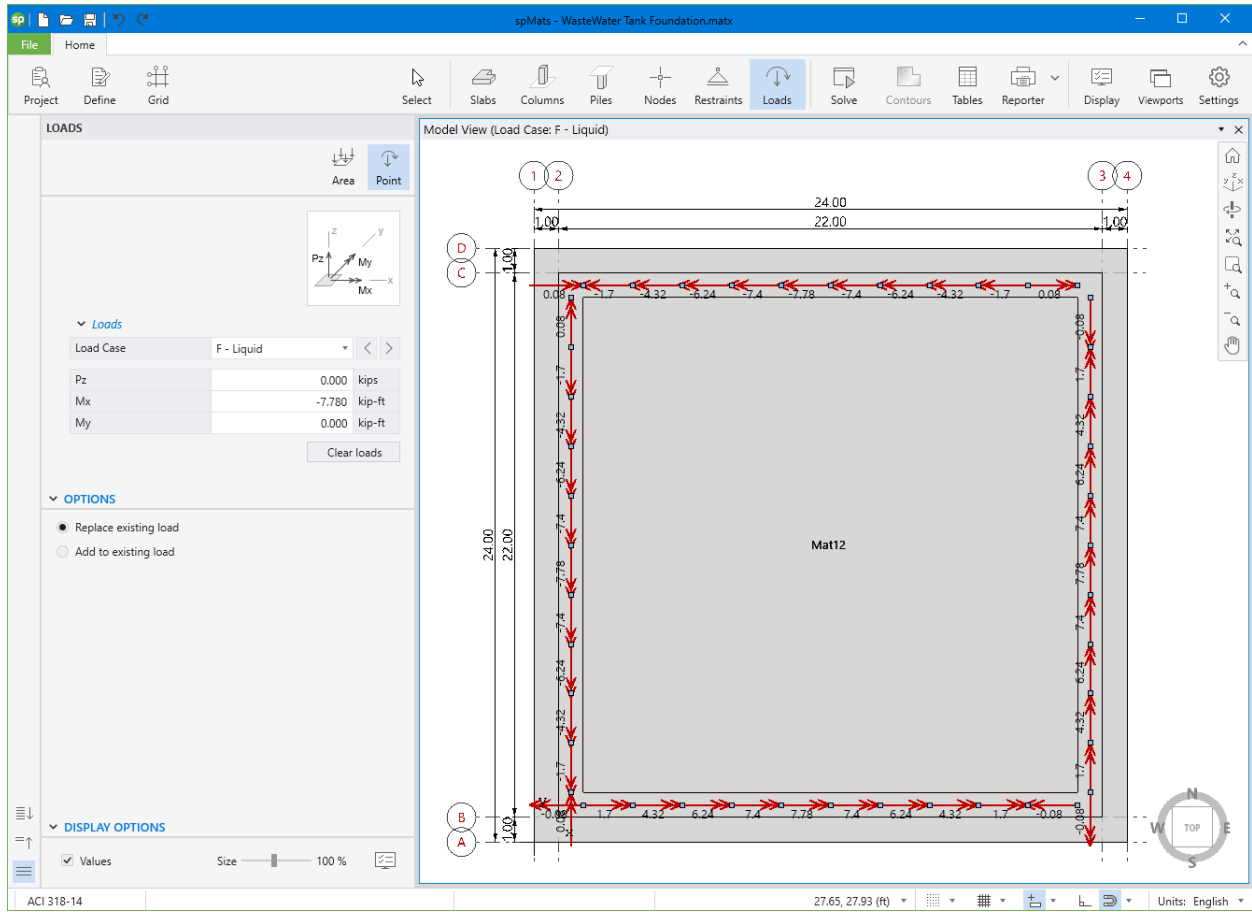

Figure 23 – Assigning Wall Liquid Reactions (spMats)

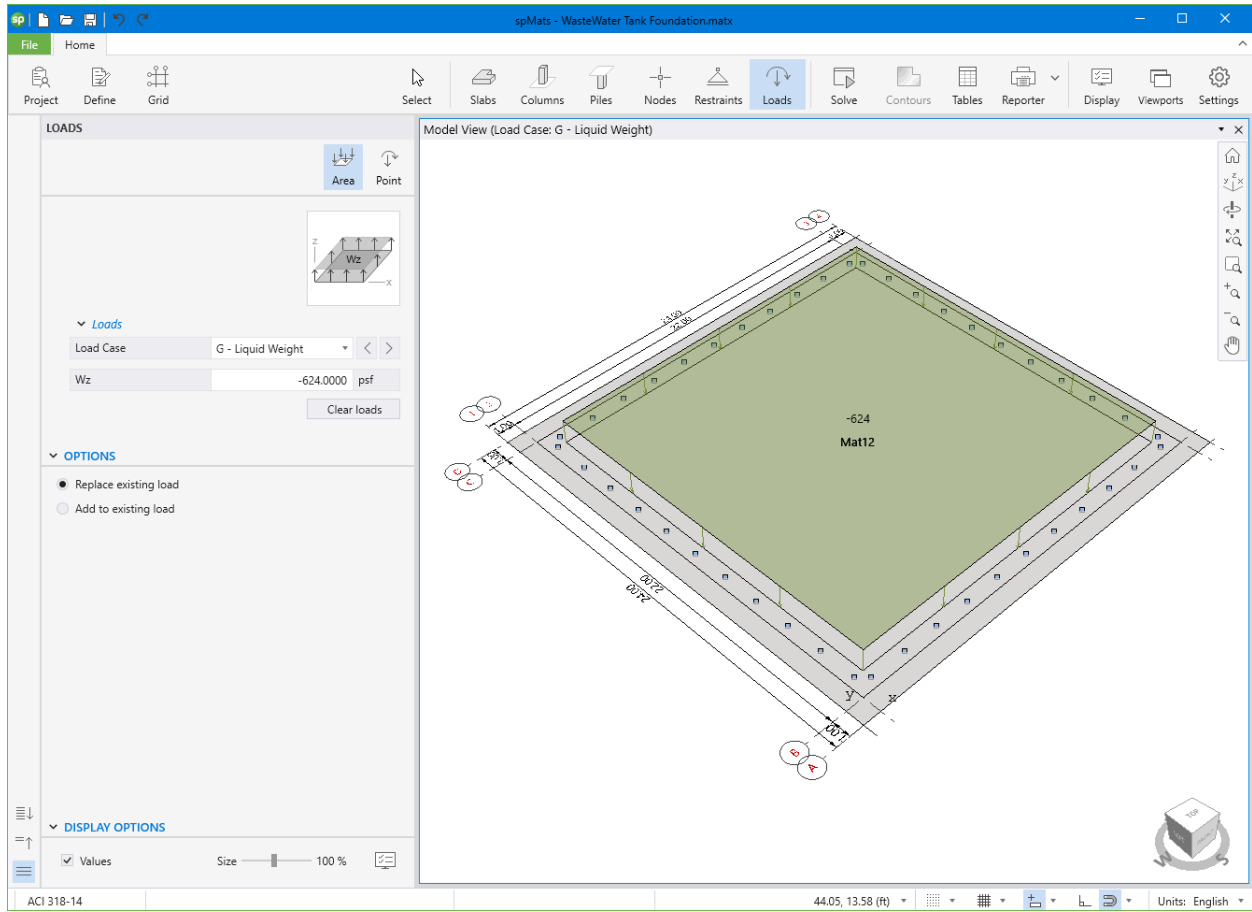

Figure 24 – Assigning Liquid Weight Loads on the Foundation (spMats)

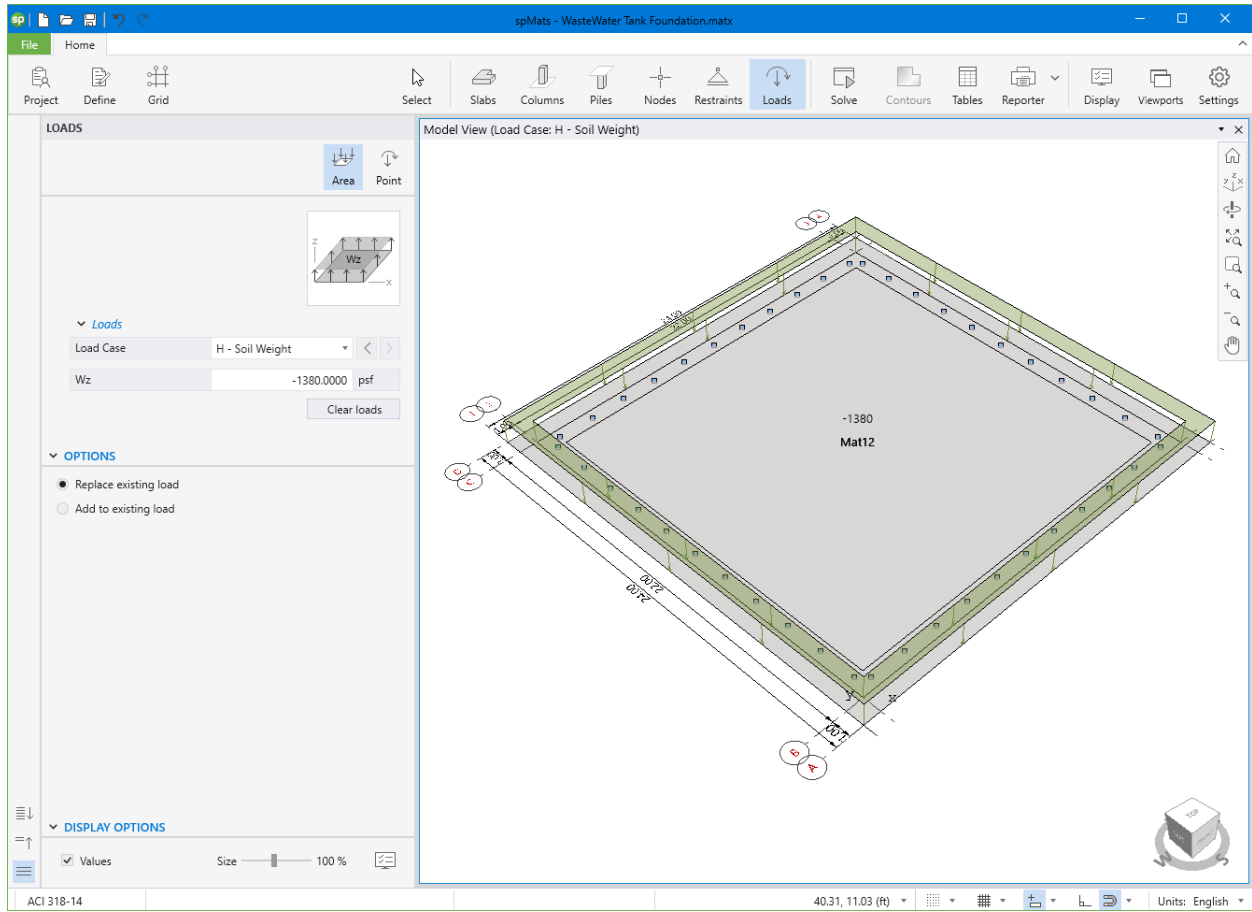

Figure 25 – Assigning Soil Weight Loads on the Foundation (spMats)

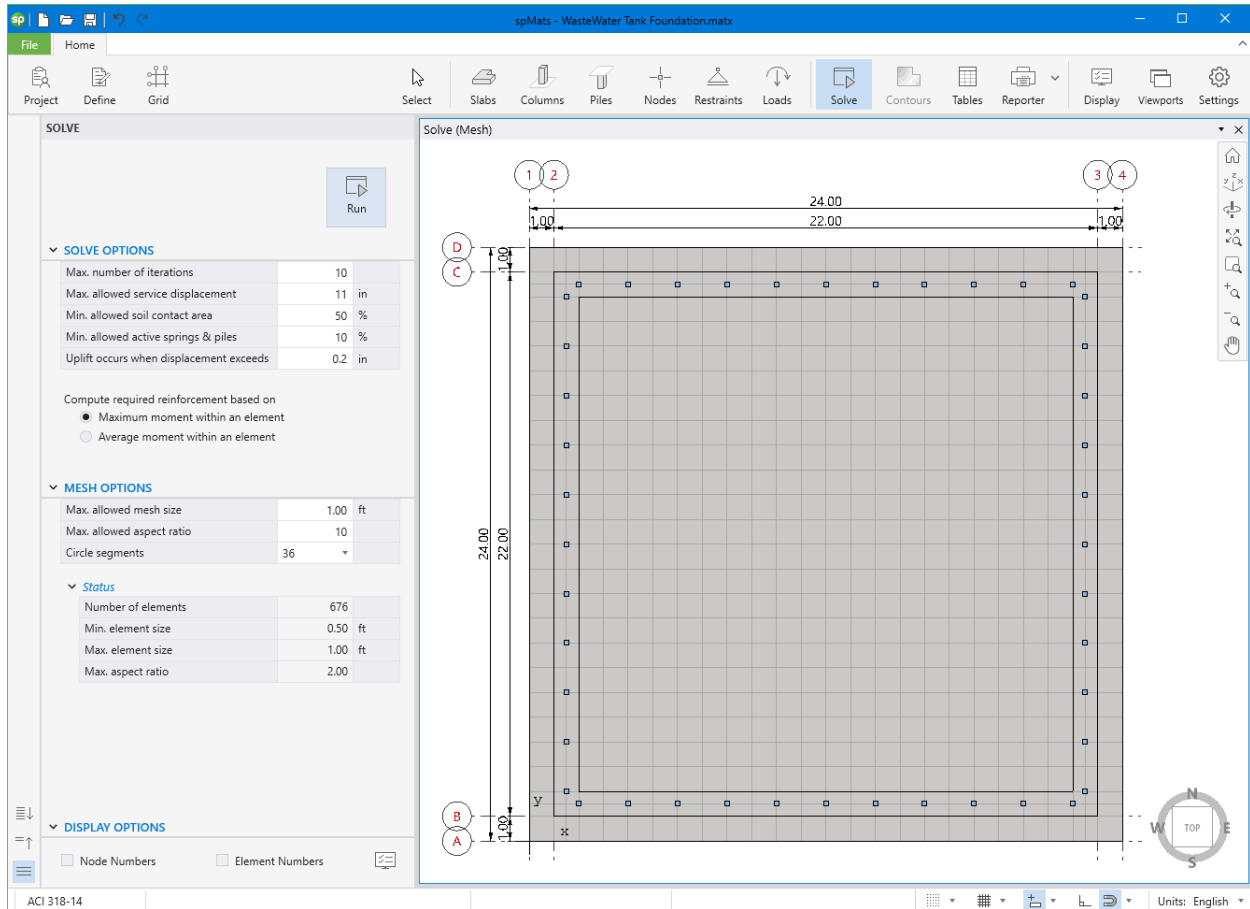

Figure 26 – Solve and Mesh Options (spMats)

11. Tank Base Mat Result Contours

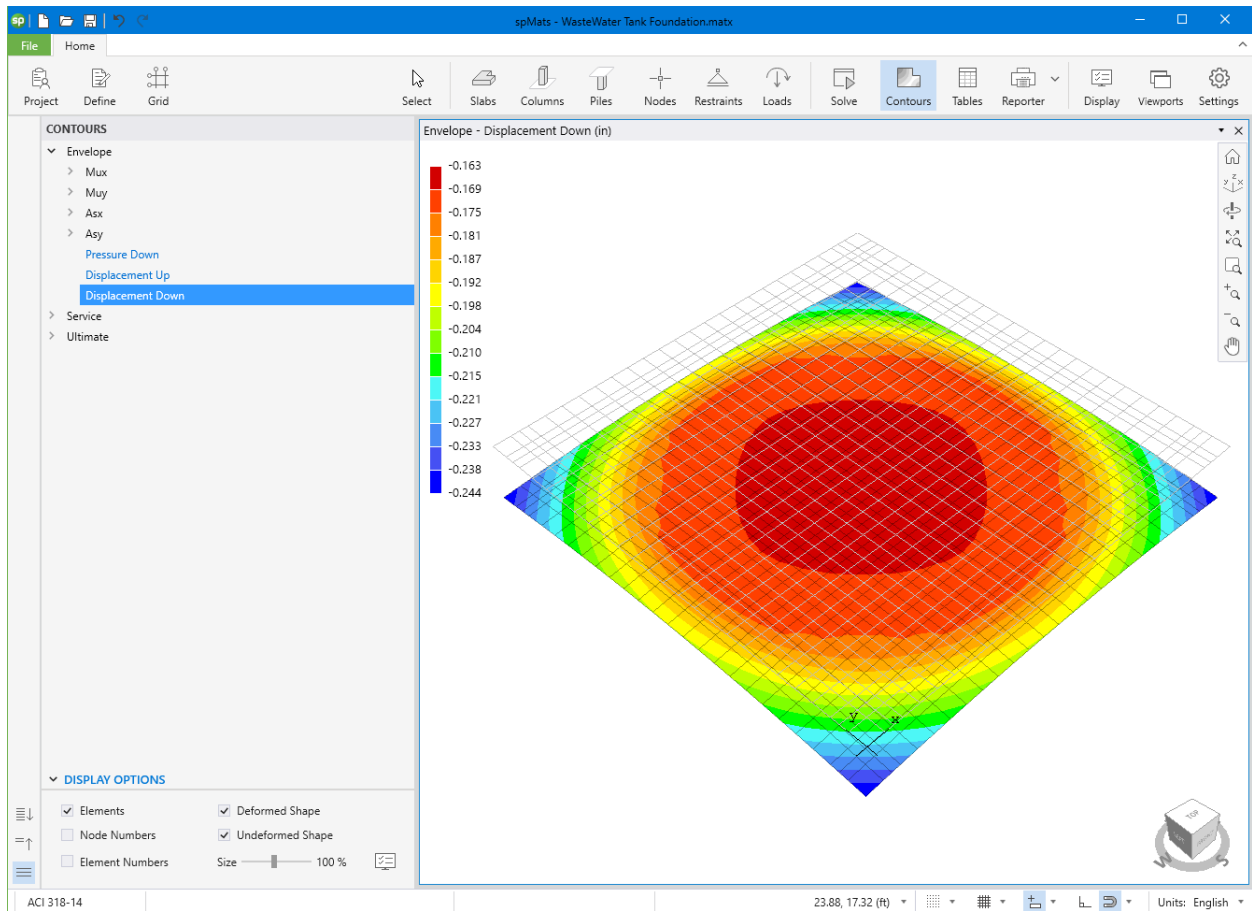

Figure 27 – Vertical (Down) Displacement Contour (spMats)

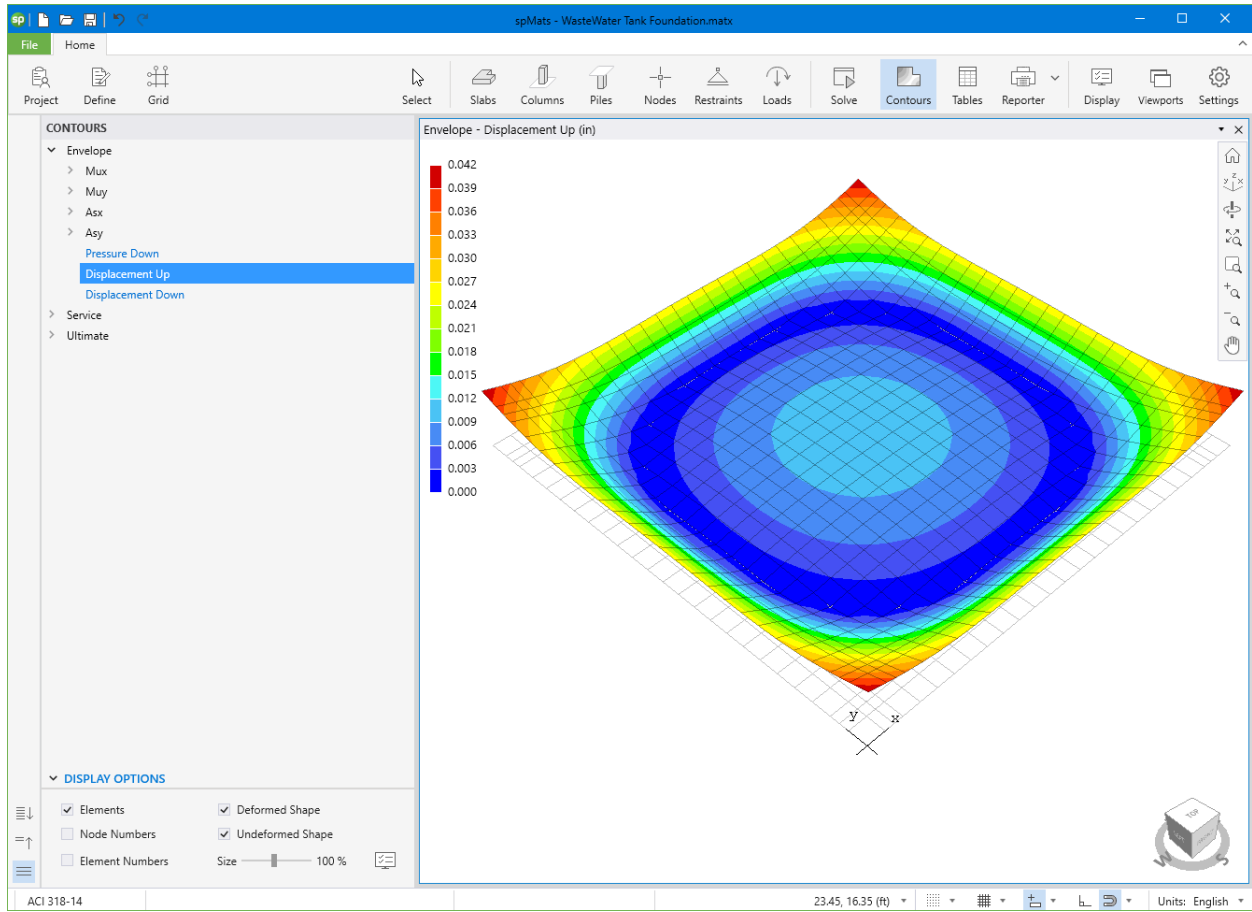

Figure 28 – Vertical (Up) Displacement Contour (spMats)

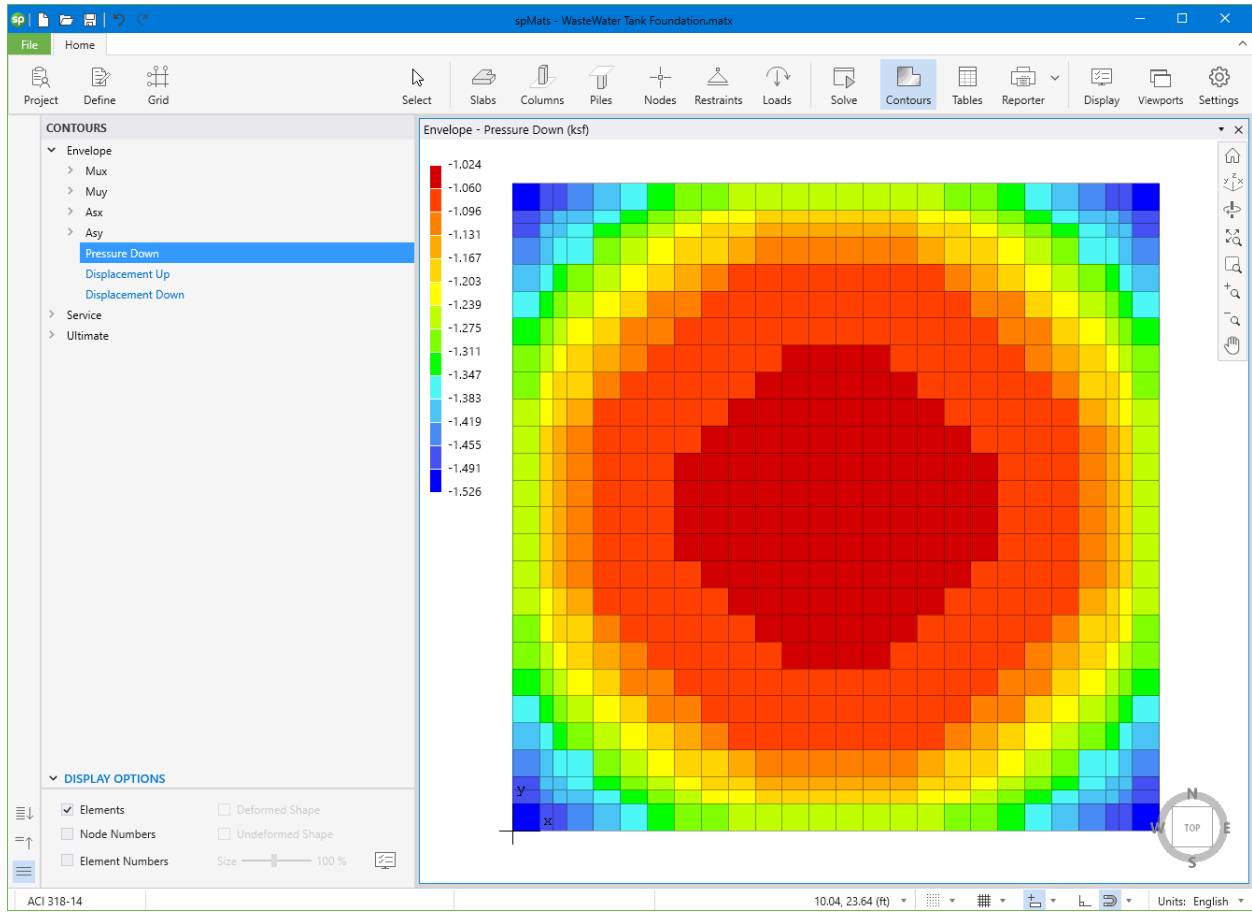

Figure 29 – Soil Pressure Envelope Contour (spMats)

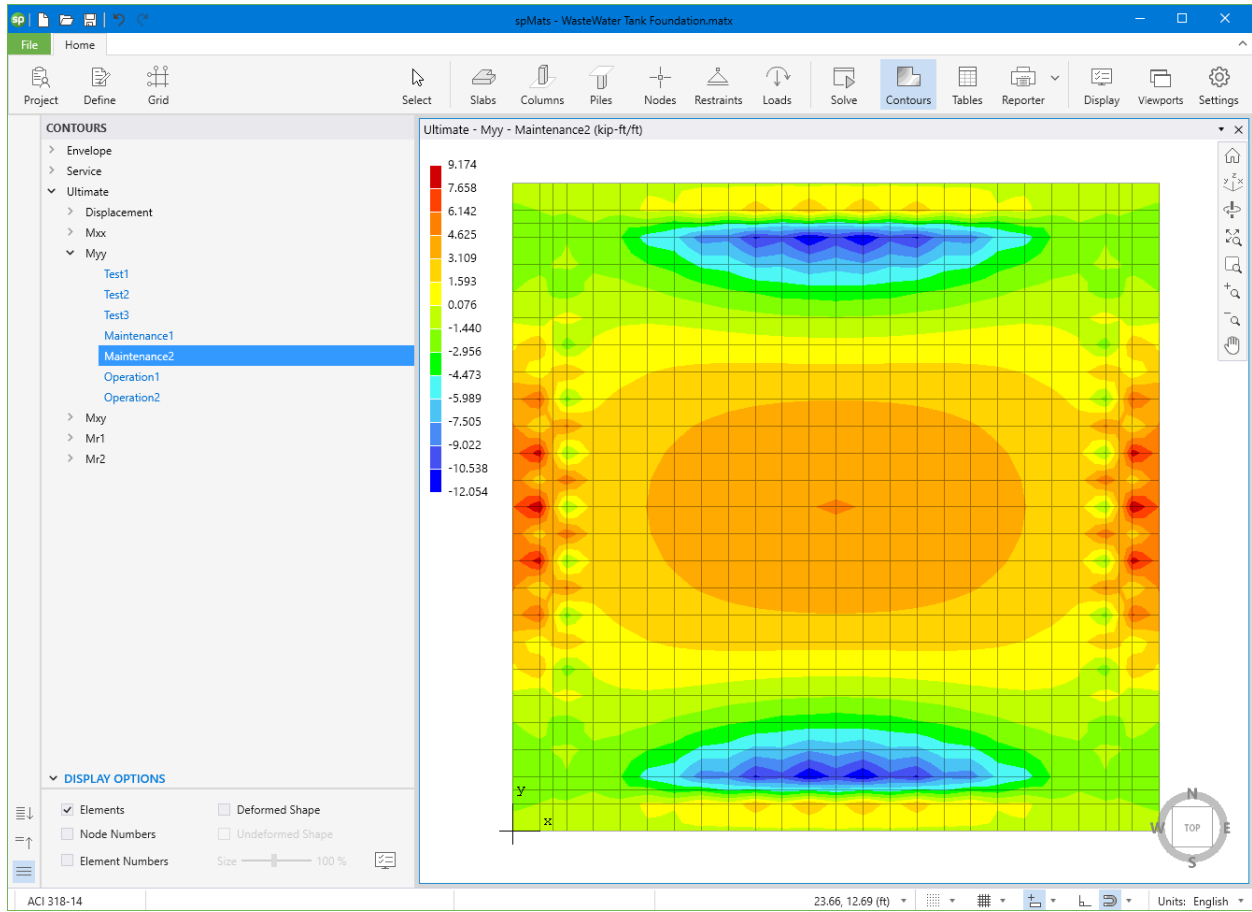

Figure 30 – Moment Contour along Y-Axis (spMats)

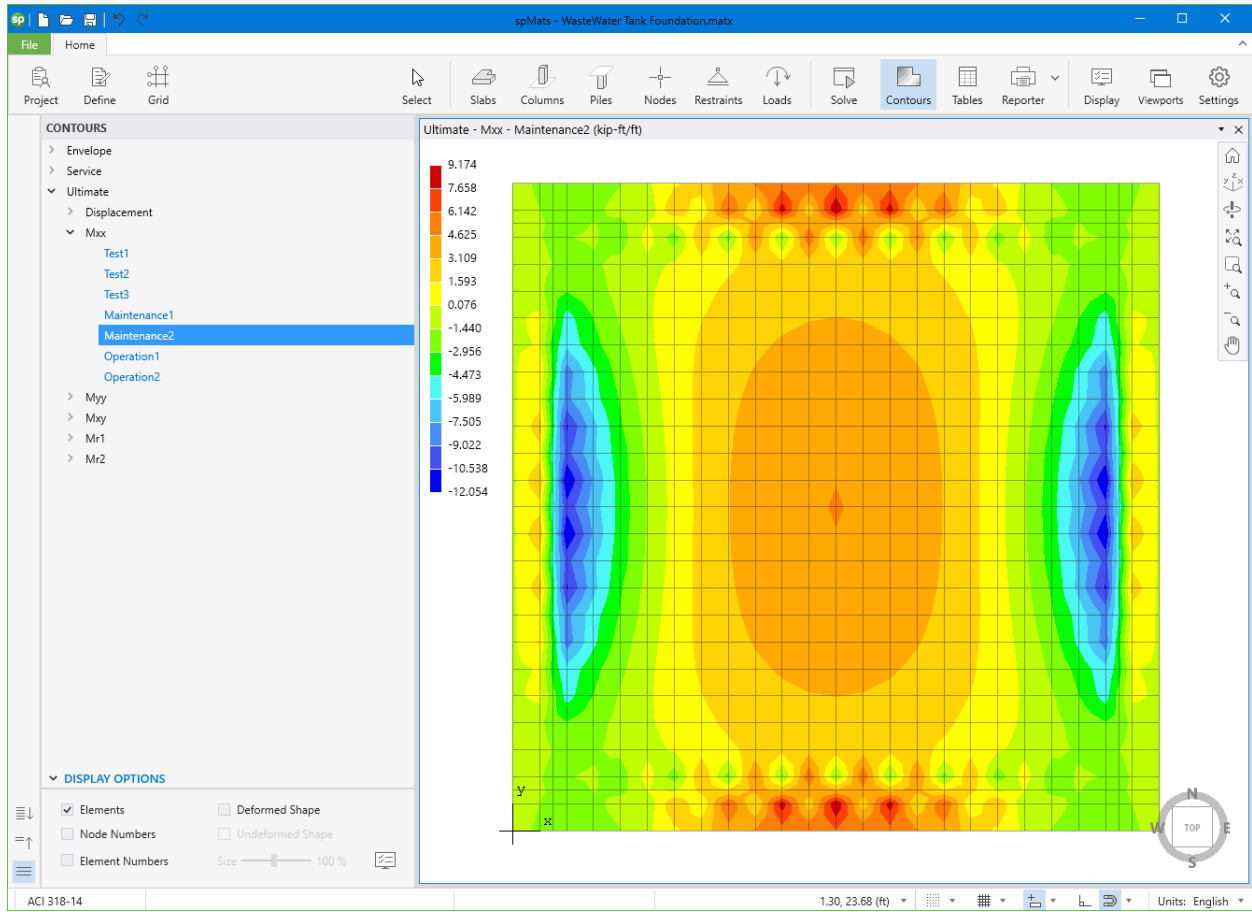

Figure 31 – Moment Contour along X-Axis (spMats)

12. Tank Base Mat Required Reinforcement

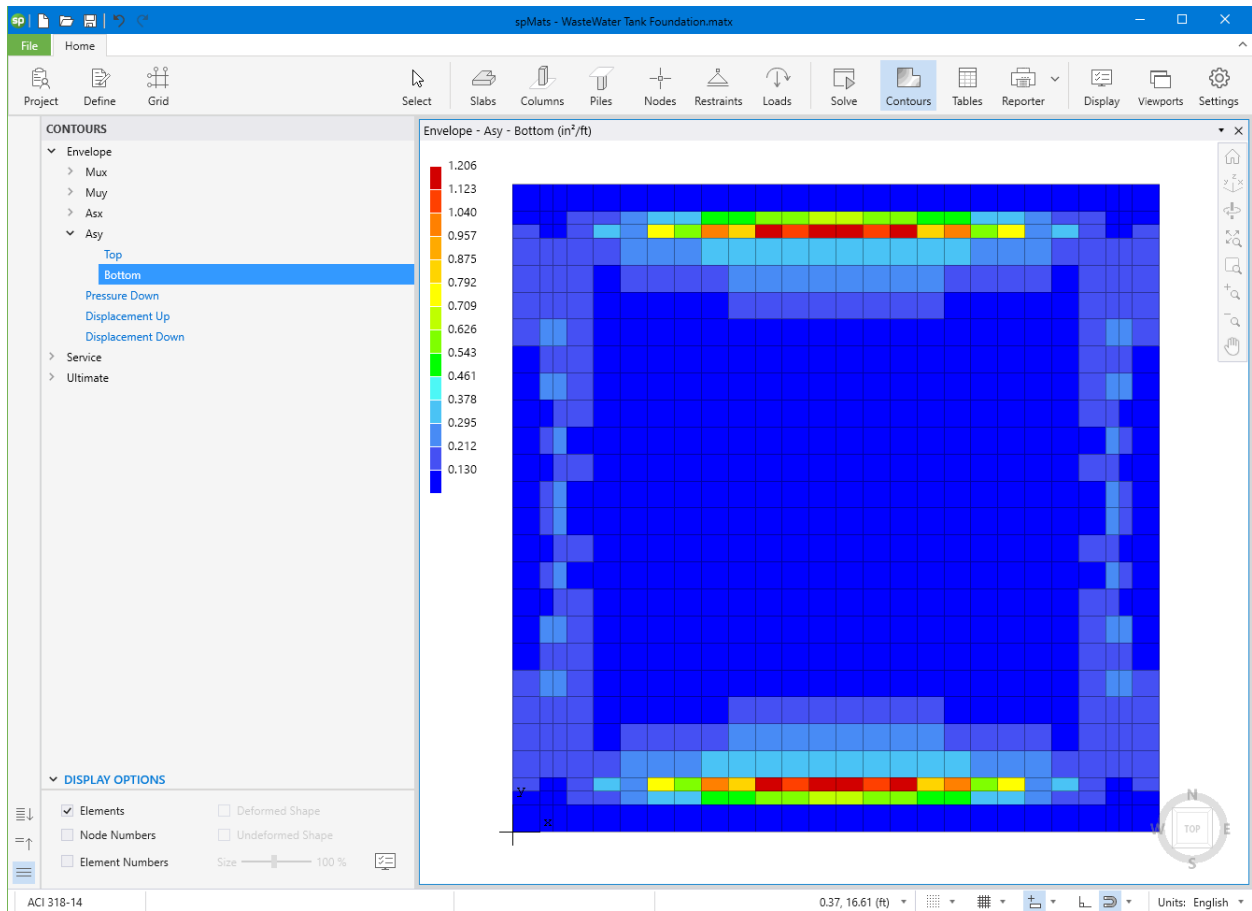

Figure 32 – Required Reinforcement Contour along Y-Direction (Bottom) (spMats)

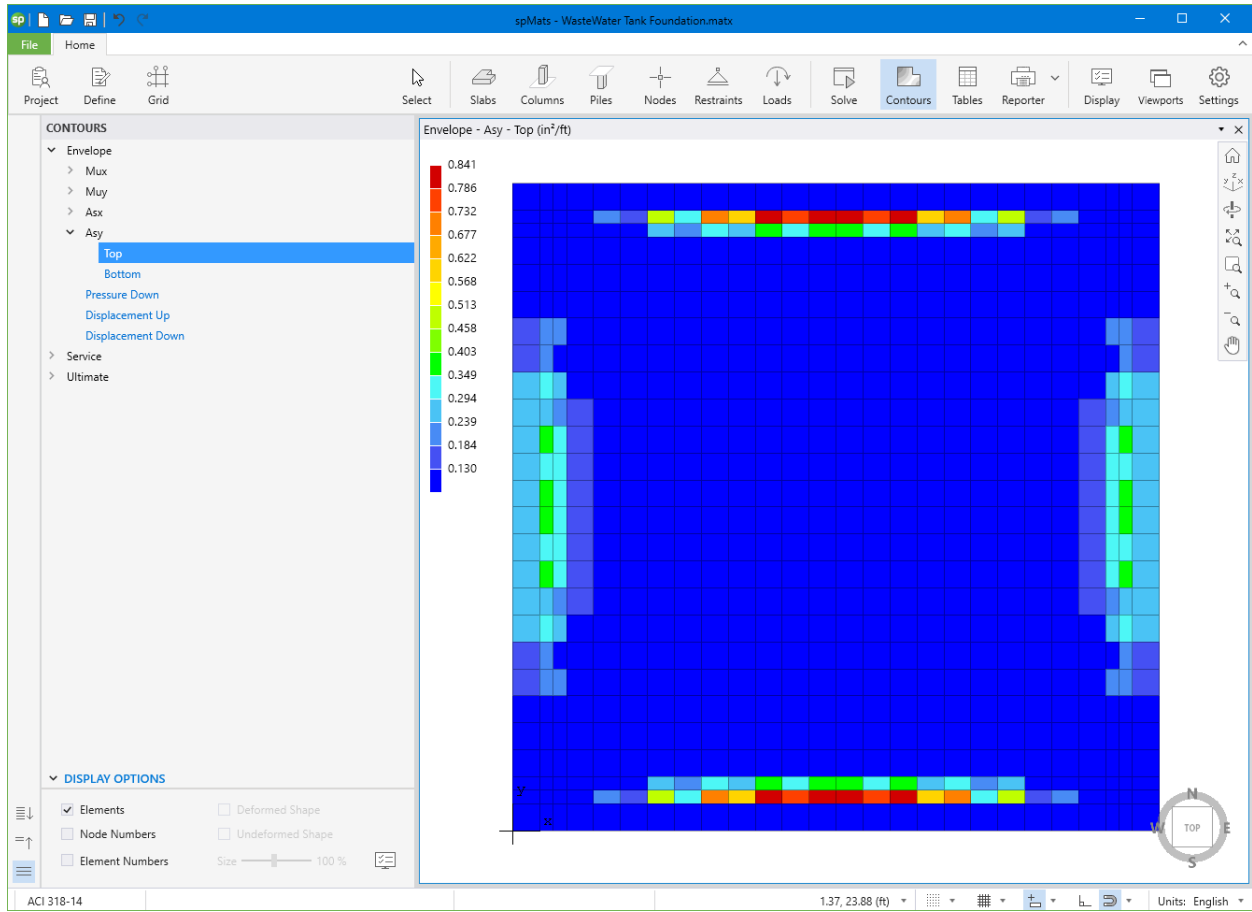

Figure 33 – Required Reinforcement Contour along Y-Direction (Top) (spMats)

13. Soil Reactions / Pressure

1. Results

1.1. Service

1.1.1. Sum of Reactions

1.1.1.1. D+H+F

NOTES:

Sum of all forces and moments with respect to center of gravity (X,Y) = (12.00, 12.00) ft

Sum of Reactions	Fz kips	Mx kip-ft	My kip-ft
Soil	618.96	0.00	0.00
Springs	-	-	-
Piles	-	-	-
Restraints	-	-	-
Slaved nodes	-	-	-
Total Reactions	618.96	0.00	0.00
Total loads	-618.96	0.00	0.00

Figure 34 – Soil Service Reactions (spMats)

1.1.2. Soil Disp. & Pressure

1.1.2.1. D+H+F

NOTES:

[x] Indicates allowable pressure is exceeded.

Element	Node	Disp, Dz in	Pressure, Qz ksf	Node	Disp, Dz in	Pressure, Qz ksf
1	29	-0.197	-1.231	2	-0.200	-1.248
	28	-0.200	-1.248	1	-0.203	-1.266
2	30	-0.196	-1.222	3	-0.198	-1.239
	29	-0.197	-1.231	2	-0.200	-1.248
3	31	-0.194	-1.213	4	-0.197	-1.229
	30	-0.196	-1.222	3	-0.198	-1.239
4	32	-0.191	-1.194	5	-0.193	-1.209
	31	-0.194	-1.213	4	-0.197	-1.229
5	33	-0.188	-1.175	6	-0.190	-1.188
	32	-0.191	-1.194	5	-0.193	-1.209
6	34	-0.185	-1.155	7	-0.187	-1.166
	33	-0.188	-1.175	6	-0.190	-1.188
7	35	-0.182	-1.135	8	-0.183	-1.145
	34	-0.185	-1.155	7	-0.187	-1.166
8	36	-0.179	-1.117	9	-0.180	-1.125
	35	-0.182	-1.135	8	-0.183	-1.145
9	37	-0.176	-1.101	10	-0.177	-1.107
	36	-0.179	-1.117	9	-0.180	-1.125
10	38	-0.174	-1.088	11	-0.175	-1.092
	37	-0.176	-1.101	10	-0.177	-1.107

Figure 35 – Soil Pressure (spMats)

14. Tank Base Mat Mesh Status

Since [spMats](#) is utilizing finite element analysis to model and design the foundation. It is useful to track the number of elements used in the model to optimize the model results (accuracy) and running time (processing stage). [spMats](#) provides mesh status to keep tracking the mesh sizing as a function of the number of elements, minimum and maximum element sizes, and maximum aspect ratio.



A screenshot of a software interface showing a table titled "Status" with a dropdown arrow. The table contains four rows of mesh data: "Number of elements" (676), "Min. element size" (0.50 ft), "Max. element size" (1.00 ft), and "Max. aspect ratio" (2.00).

▼ Status		
Number of elements	676	
Min. element size	0.50	ft
Max. element size	1.00	ft
Max. aspect ratio	2.00	

Figure 36 – Mesh Status ([spMats](#))

15. Tank Analysis Design Observation & Conclusions

The evaluation of the load combination requires a thorough evaluation of the construction, backfill, test, commissioning, maintenance, and repair stages required throughout the entire tank service life. The list used in this case study is just a partial set chosen for illustration.

Designer is advised to take the care required in exporting the wall reactions carefully to the base mat model to ensure completeness and accuracy in the sign convention.

The effect of buoyancy is not shown in this case study as the water table was assumed to be below the bottom of the tank. Additional loading considerations would have to be added to adequately address this condition.