

**Combined Axial Force and Biaxial Bending Interaction Diagram – Square Reinforced Concrete Column (ACI 318-14)**

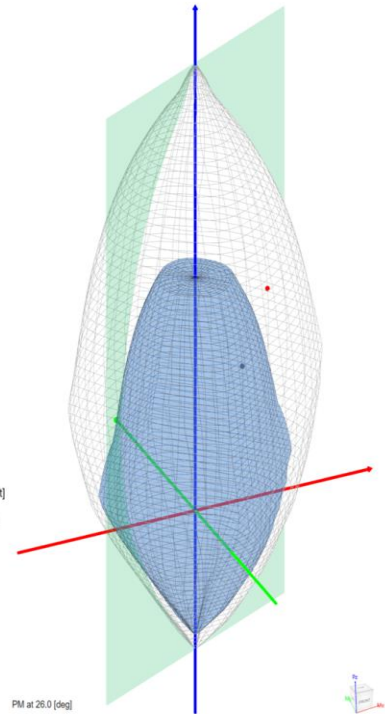
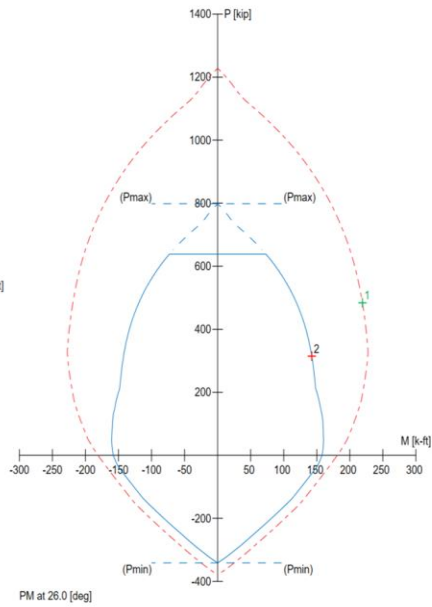
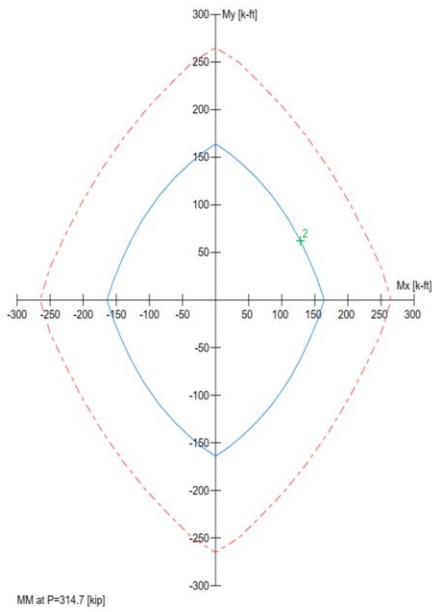
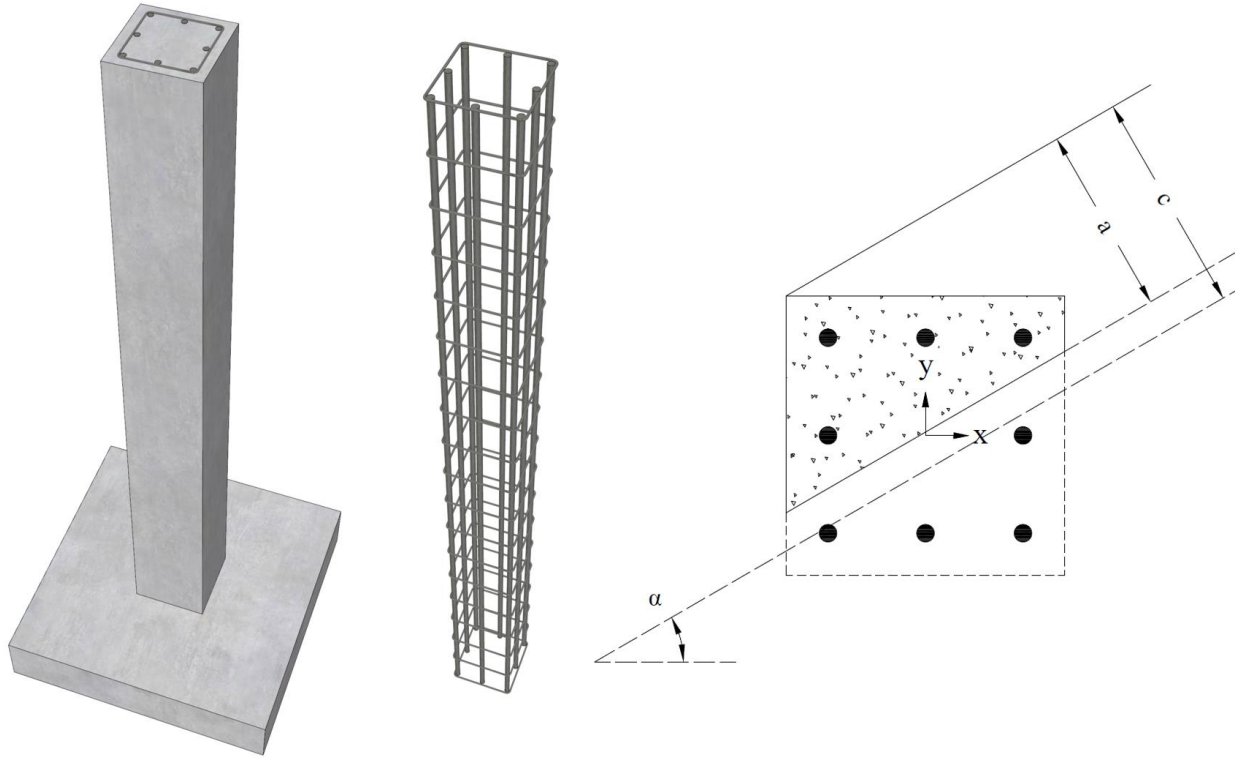

## Combined Axial Force and Biaxial Bending Interaction Diagram - Square Reinforced Concrete Column (ACI 318-14)

Biaxial bending of columns occurs when the loading causes bending simultaneously about both principal axes. The commonly encountered case of such loading occurs in corner columns. Corner and other columns exposed to known moments about each axis simultaneously should be designed for biaxial bending and axial load.

A uniaxial interaction diagram defines the load-moment strength along a single plane of a section under an axial load  $P$  and a uniaxial moment  $M$ . The biaxial bending resistance of an axially loaded column can be represented schematically as a surface formed by a series of uniaxial interaction curves drawn radially from the  $P$  axis. Data for these intermediate curves are obtained by varying the angle of the neutral axis (for assumed strain configurations) with respect to the major axes.

The difficulty associated with the determination of the strength of reinforced columns subjected to combined axial load and biaxial bending is primarily an arithmetic one. The bending resistance of an axially loaded column about a particular skewed axis is determined through iterations involving simple but lengthy calculations. These extensive calculations are compounded when optimization of the reinforcement or cross-section is sought.

This example demonstrates the determination of the design axial load capacity,  $\phi P_n$ , and the design  $\phi M_{nx}$  and  $\phi M_{ny}$  moments corresponding to the following case: The neutral axis position crosses the vertical axis of symmetry of the section ( $y$ -axis) at 10 in. below the top of the section, at an angle of  $30^\circ$  counterclockwise from the  $x$ -axis of the cross section. The figure below shows the reinforced concrete square column cross section in consideration. We will compare the calculated values of the column axial strength and biaxial bending strength with the values from the reference and the exact values from [spColumn](#) engineering software program from [StructurePoint](#). The steps to develop the three-dimensional failure surface (interaction diagram) using [spColumn](#) will be shown in detail as well.

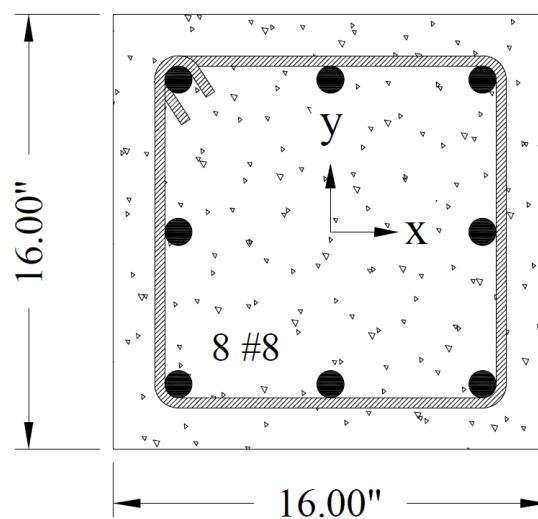

Figure 1 – Reinforced Concrete Column Cross-Section

## Contents

1. Concrete Column Biaxial Strength Calculations.....	5
1.1. Location of Neutral Axis and Concrete Compression Force.....	6
1.2. Strains and Forces Determination in Reinforcement Layers.....	7
1.3. Calculation of $P_n$ , $M_{nx}$ and $M_{ny}$ .....	8
2. Column Biaxial Bending Interaction Diagram – spColumn Software .....	9
3. Summary and Comparison of Design Results.....	21
4. Conclusions & Observations .....	22

**Code**

Building Code Requirements for Structural Concrete (ACI 318-14) and Commentary (ACI 318R-14)

**Reference**

Reinforced Concrete Mechanics and Design, 7th Edition, 2016, James Wight, Pearson, Example 11-5

Notes on ACI 318-11 Building Code Requirements for Structural Concrete, Twelfth Edition, 2013 Portland Cement Association

[spColumn Engineering Software Program Manual v6.50](#), StructurePoint, 2019

**Design Data**

$f_c' = 4000$  psi

$f_y = 60000$  psi

Cover = 2.4 in.

Column dimensions and reinforcement locations are shown in following figure.

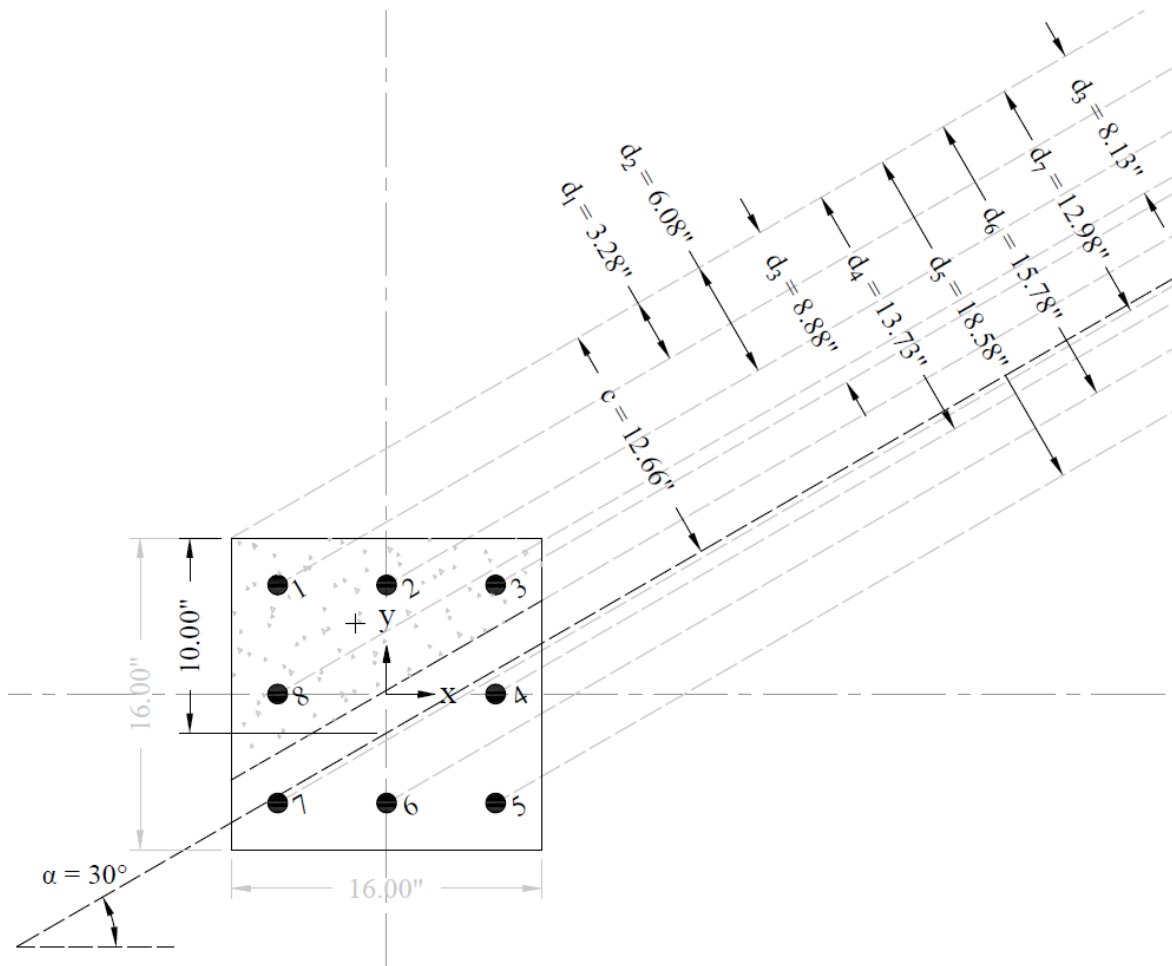

**Figure 2 – Reinforced Concrete Column Cross-Section and Reinforcement Locations**

**Solution**

In a reinforced concrete column, the determination of the nominal axial load capacity,  $P_n$ , and the nominal  $M_{nx}$  and  $M_{ny}$  moments involves a trial-and-error process for calculating the neutral axis depth and angle  $\alpha$ . The reference provided the neutral axis depth and angle as an input (The neutral axis position crosses the vertical axis of symmetry of the section at 10 in. leading to  $c = 12.66$  in. and an angle of  $\alpha = 30.0^\circ$ ) for illustration.

The steps to calculate biaxial flexural strength of a reinforced concrete column for a given nominal axial strength and moment ratio of biaxial bending moments is discussed in details in “[Combined Axial Force and Biaxial Bending Interaction Diagram - Rectangular Reinforced Concrete Column \(ACI 318-14\)](#)” design example.

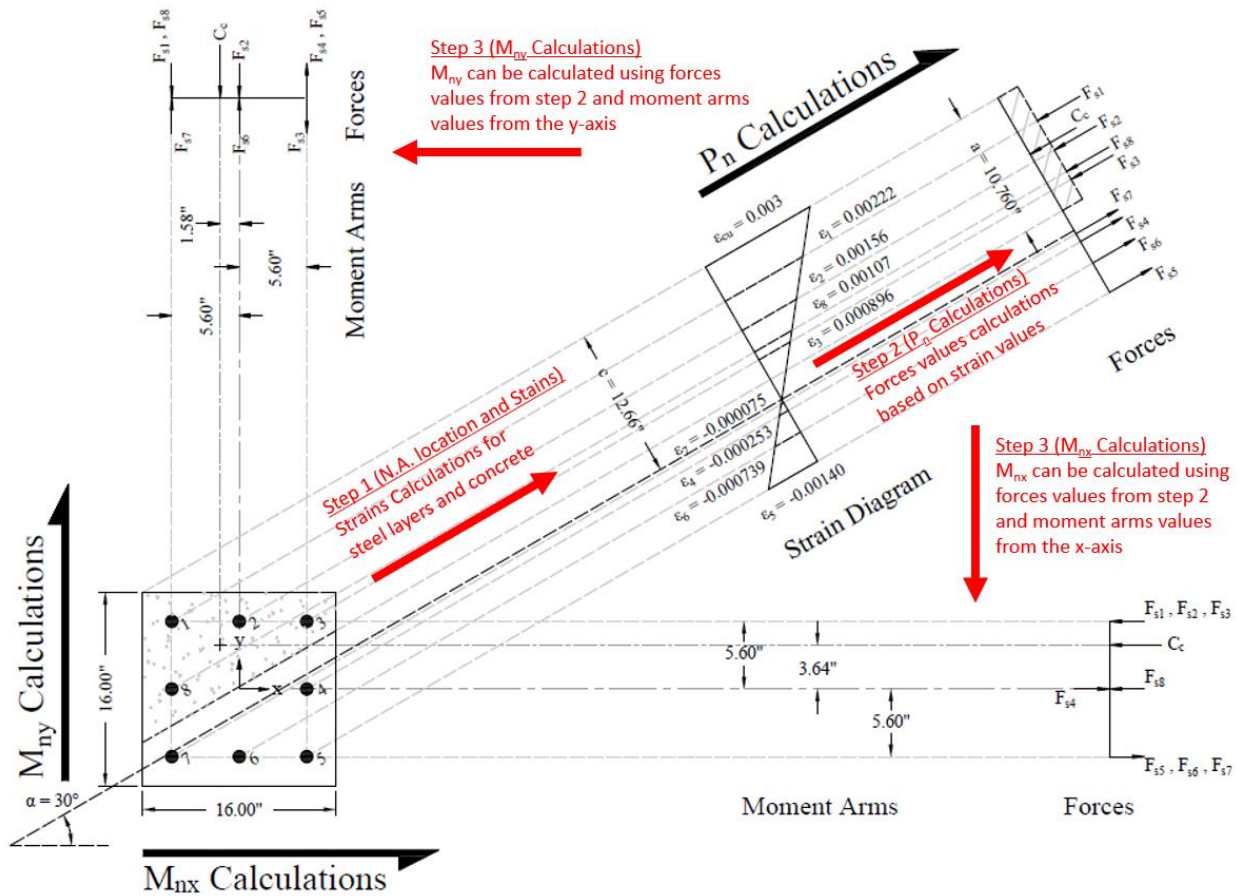

Figure 3 – Nominal Axial Load and Biaxial Flexural Strength Calculation Methods for a Reinforced Concrete Column.

1. Concrete Column Biaxial Strength Calculations

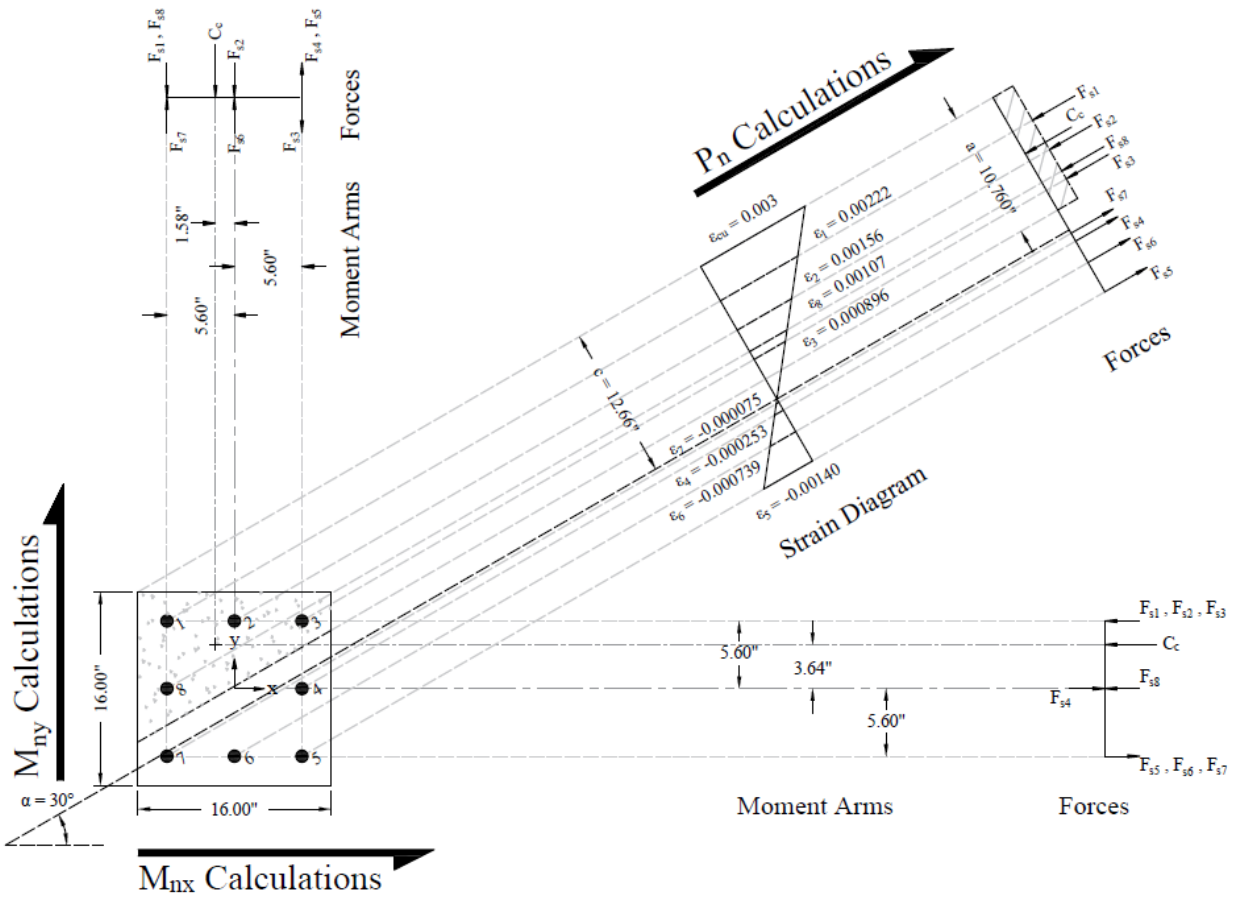

Figure 4 – Strains, Forces, and Moment Arms Diagram

### 1.1. Location of Neutral Axis and Concrete Compression Force

The trial-and-error process for calculating the neutral axis depth and angle  $\alpha$  is not required in this example since these values are given by the reference ( $c = 12.66$  in. and  $\alpha = 30.0^\circ$ ). Where  $c$  is the distance from the fiber of maximum compressive strain to the neutral axis and  $\alpha$  is the angle of the neutral axis.

ACI 318-14 (22.2.2.4.2)

$$\varepsilon_y = \frac{f_y}{E_s} = \frac{60}{29,000} = 0.00207$$

$$\varepsilon_{s5} = (c - d_s) \times \frac{\varepsilon_{cu}}{c} = (12.66 - 18.578) \times \frac{0.003}{12.66} = -0.00140 \text{ (Tension)} < \varepsilon_y \rightarrow \text{reinforcement has not yielded}$$

$$\therefore \phi = 0.65$$

ACI 318-14 (Table 21.2.2)

$$a = \beta_1 \times c = 0.85 \times 12.66 = 10.761 \text{ in.}$$

ACI 318-14 (22.2.2.4.1)

$$\varepsilon_{cu} = 0.003$$

ACI 318-14 (22.2.2.1)

Where:

$a$  = Depth of equivalent rectangular stress block

ACI 318-14 (Table 22.2.2.4.3)

$$\beta_1 = 0.85 - \frac{0.05 \times (f'_c \times 4000)}{1000} = 0.85 - \frac{0.05 \times (4000 - 4000)}{1000} = 0.85$$

ACI 318-14 (Table 22.2.2.4.3)

$$C_c = 0.85 \times f'_c \times A_{comp} = 0.85 \times 4000 \times 124.88 = 424.59 \text{ kip (Compression)}$$

ACI 318-14 (22.2.2.4.1)

Where (see the following figure):

$$A_{comp} = A_1 + A_2 = \left( \frac{1}{2} \times 9.24 \times 16 \right) + (3.19 \times 16) = 124.88 \text{ in.}^2$$

$$\bar{x} = \left( \frac{A_1 \times \bar{x}_1 + A_2 \times \bar{x}_2}{A_1 + A_2} \right) - 8.00 = \left( \frac{73.84 \times 5.33 + 51.04 \times 8.00}{73.84 + 51.04} \right) - 8.00 = -1.58 \text{ in.}$$

$$\bar{y} = \left( \frac{A_1 \times \bar{y}_1 + A_2 \times \bar{y}_2}{A_1 + A_2} \right) - 4.42 = \left( \frac{73.84 \times 6.153 + 51.04 \times 18.825}{73.84 + 51.04} \right) - 4.42 = 3.64 \text{ in.}$$

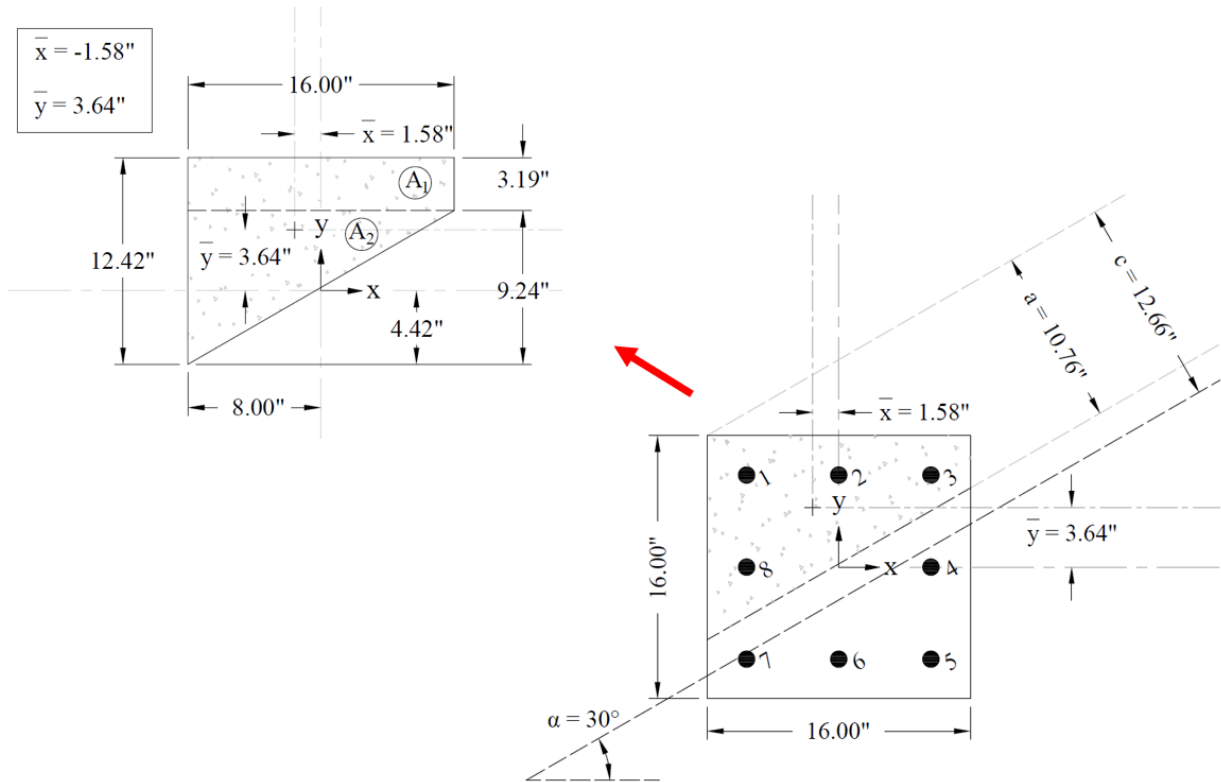

**Figure 5 – Cracked Concrete Column Section Centroid Calculations**

**1.2. Strains and Forces Determination in Reinforcement Layers**

The following shows the calculations of forces in the reinforcement layers with the extreme tension (at bar 5) and extreme compression (at bar 1) strains. The calculations for the rest of layers are shown the table at the end of this section.

For extreme tension reinforcement layer (at bar 5):

$$\epsilon_{s5} = -0.00140 \text{ (Tension)} < \epsilon_y \rightarrow \text{reinforcement has not yielded}$$

$$\therefore f_{s5} = \epsilon_{s5} \times E_s = -0.00140 \times 29000000 = -40669 \text{ psi}$$

$$F_{s5} = f_{s5} \times A_{s5} = -40669 \times (1 \times 0.79) = -32.13 \text{ kip (Tension)}$$

For extreme compression reinforcement layer (at bar 1):

$$\epsilon_{s1} = (c - d_1) \times \frac{\epsilon_{cu}}{c} = (12.66 - 3.278) \times \frac{0.003}{12.66} = 0.00222 \text{ (Compression)} > \epsilon_y \rightarrow \text{reinforcement has yielded}$$

$$\therefore f_{s1} = f_y = 60000 \text{ psi}$$



The area of the reinforcement in this layer is included in the area used to compute  $C_c$  ( $a = 10.76 \text{ in.} > d_1 = 3.28 \text{ in.}$ ). As a result, it is necessary to subtract  $0.85f_c'$  from  $f_{s1}$  before computing  $F_{s1}$ :

$$F_{s1} = f_{s1} \times A_{s1} = (60000 - 0.85 \times 4000) \times (1 \times 0.79) = 44.71 \text{ kip (Compression)}$$

The same procedure shown above can be repeated to calculate the forces in the remaining reinforcement locations, results are summarized in the following table:

Table 1 - Strains, internal force resultants and Moments									
Location	d, in.	$\epsilon$ , in./in.	$f_s$ , psi	$F_s$ , kip	$C_c$ , kip	Moment arm (x), in.	$M_y$ , kip-ft	Moment arm (y), in.	$M_x$ , kip-ft
Concrete	---	0.00300	---	---	424.59	1.58	55.90	3.64	128.79
Bar 1	3.278	0.00222	60000	44.71*	---	2.4	20.87	2.4	20.87
Bar 2	6.078	0.00156	45232	33.05*	---	8.0	0.00	2.4	15.42
Bar 3	8.878	0.00090	25990	17.85*	---	13.6	-8.33	2.4	8.33
Bar 4	13.728	-0.00025	-7339	-5.8	---	13.6	2.71	8.0	0.00
Bar 5	18.578	-0.00140	-40669	-32.13	---	13.6	14.99	13.6	14.99
Bar 6	15.778	-0.00074	-21427	-16.93	---	8.0	0.00	13.6	7.90
Bar 7	12.978	-0.00008	-2185	-1.73	---	2.4	-0.81	13.6	0.81
Bar 8	8.128	0.00107	31144	21.92*	---	2.4	10.23	8.0	0.00
Axial Force and Biaxial Bending Moments Capacities			$P_n$ , kip	485.54		$M_{ny}$ , kip-ft	95.56	$M_{nx}$ , kip-ft	197.11
			$\phi P_n$ , kip	315.60		$\phi M_{ny}$ , kip-ft	62.12	$\phi M_{nx}$ , kip-ft	128.12

\* The area of the reinforcement in this layer has been included in the area used to compute  $C_c$ . As a result,  $0.85f_c'$  is subtracted from  $f_s$  in the computation of  $F_s$ .

### 1.3. Calculation of $P_n$ , $M_{nx}$ and $M_{ny}$

$$P_n = C_c + \sum F_s \quad (+) = \text{Compression} \quad (-) = \text{Tension}$$

$$\phi P_n = \phi \times P_n = 0.65 \times P_n$$

$$M_{ny} = C_c \times \left( \frac{b}{2} - \bar{x}_c \right) + \sum_{i=1}^{n=10} \left( F_{si} \times \left( \frac{b}{2} - x_i \right) \right) \quad (+) = \text{Counter Clockwise} \quad (-) = \text{Clockwise}$$

$$\phi M_{ny} = \phi \times M_{ny} = 0.65 \times M_{ny}$$

$$M_{nx} = C_c \times \left( \frac{h}{2} - \bar{y}_c \right) + \sum_{i=1}^{n=10} \left( F_{si} \times \left( \frac{h}{2} - y_i \right) \right) \quad (+) = \text{Counter Clockwise} \quad (-) = \text{Clockwise}$$

$$\phi M_{nx} = \phi \times M_{nx} = 0.65 \times M_{nx}$$

## 2. Column Biaxial Bending Interaction Diagram – spColumn Software

[spColumn](#) program performs the analysis of the reinforced concrete section conforming to the provisions of the Strength Design Method and Unified Design Provisions with all conditions of strength satisfying the applicable conditions of equilibrium and strain compatibility. For this column section, we ran in investigation mode with “**biaxial**” option for “Run Axis” using the ACI 318-14.

For biaxial runs, the values of maximum compressive axial load capacity and maximum tensile load capacity are computed. These two values set the range within which the moment capacities are computed for a predetermined number of axial load values. For each level of axial load, the section is rotated in 10-degree increments from 0 degrees to 360 degrees and the  $M_x$  and  $M_y$  moment capacities are computed. Thus, for each level of axial load, an  $M_x$ - $M_y$  contour is developed. Repeating this for the entire range of axial loads, the three-dimensional failure surface is computed. A three-dimensional visualization of the resulting entire nominal and factored failure surface is provided to support enhanced understanding of the section capacity.

The “**biaxial**” feature allows the user to investigate the P-M interaction diagrams, the  $M_x$ - $M_y$  moment contour plots, as well as the 3D failure surface for even the most irregular column and shear wall sections quickly, simply, and accurately.

In lieu of using program shortcuts, [spColumn](#) model editor was used to place the reinforcement and define the cover to illustrate handling of irregular shapes and unusual bar arrangement.

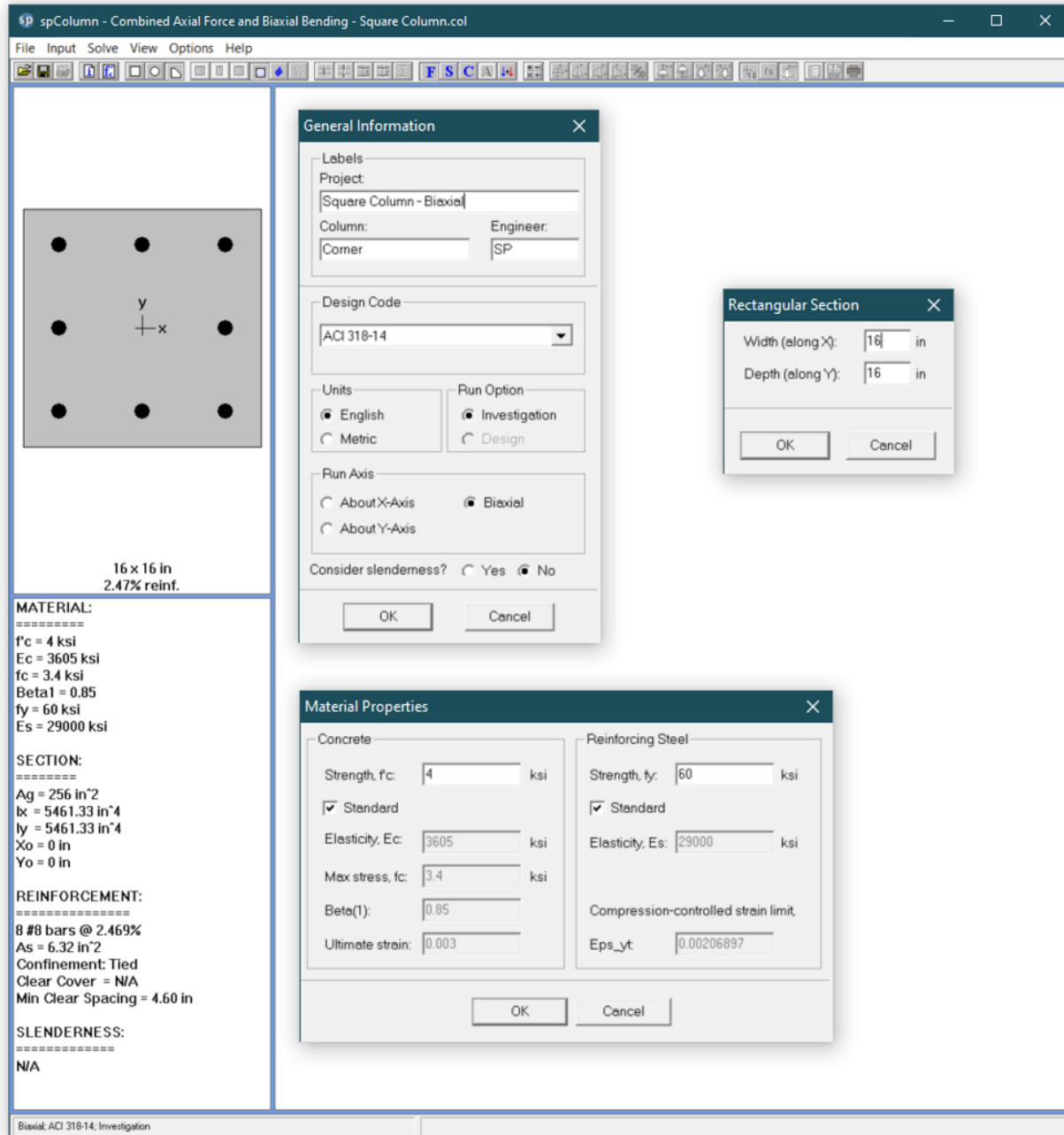

Figure 6 – Generating spColumn Model

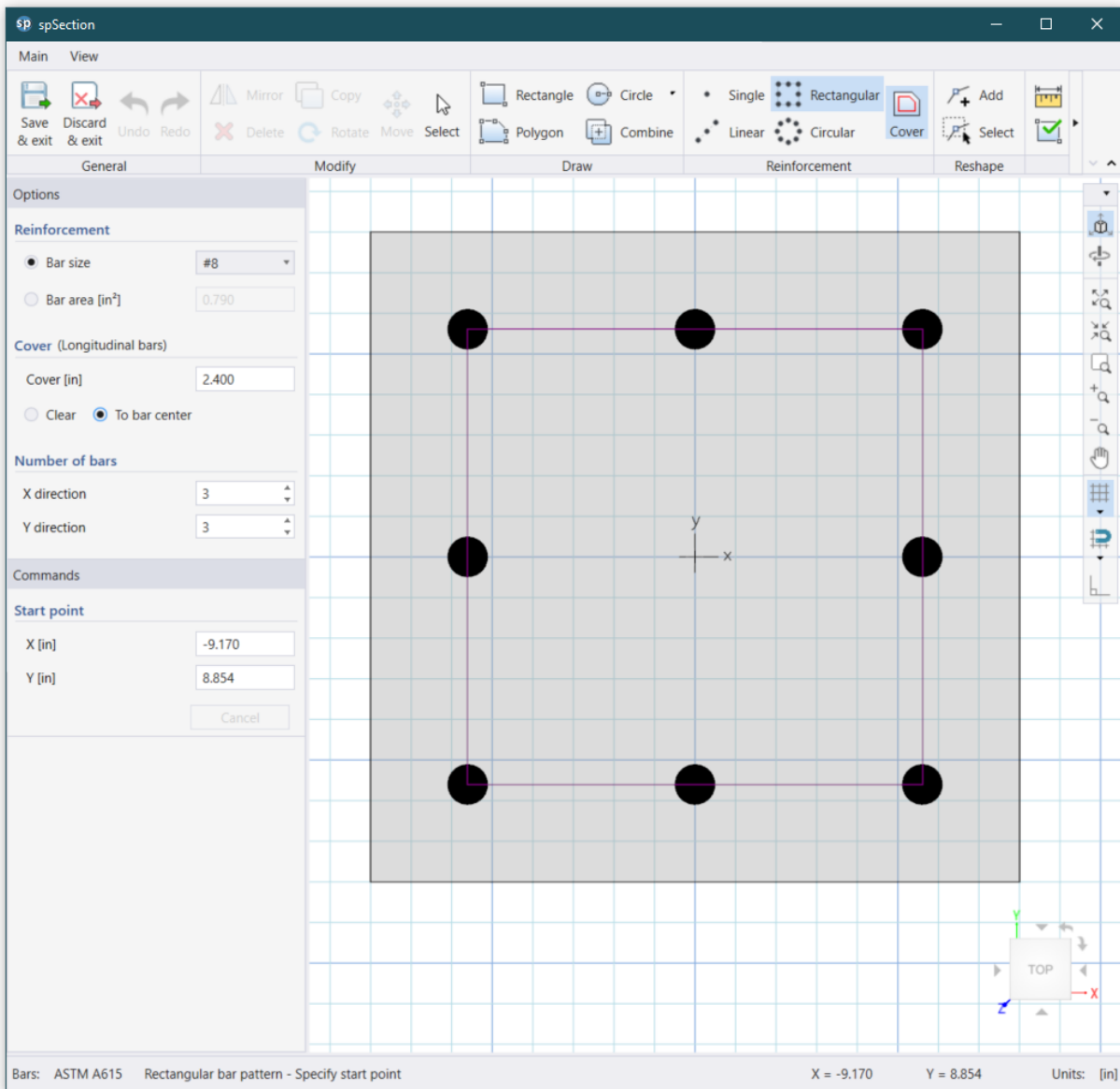

Figure 7 – spColumn Model Editor (spSection)

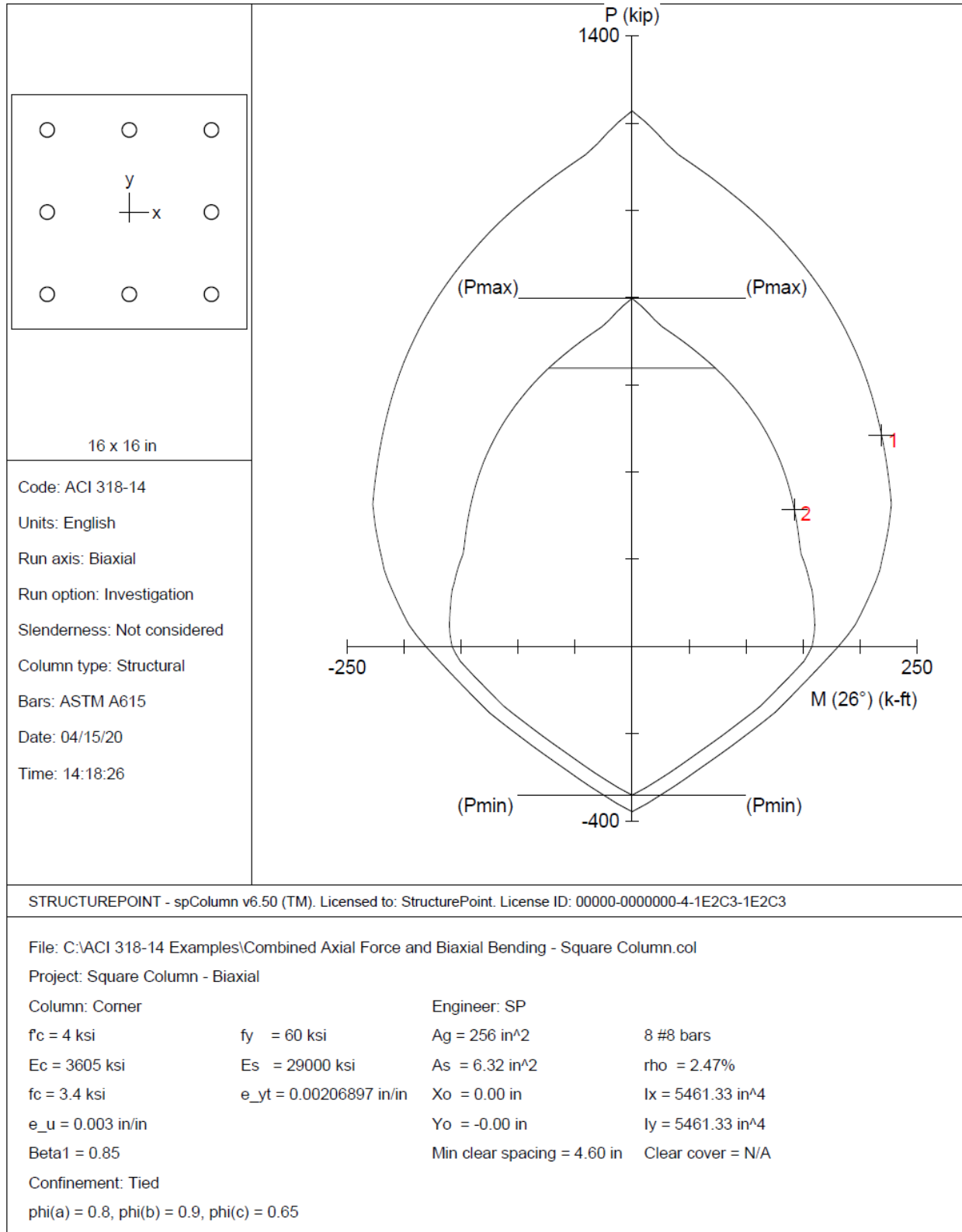

Figure 8 – Column Section Interaction Diagram at 26° (spColumn)



---

spColumn v6.50  
Computer program for the Strength Design of Reinforced Concrete Sections  
Copyright - 1988-2020, STRUCTUREPOINT, LLC.  
All rights reserved

---

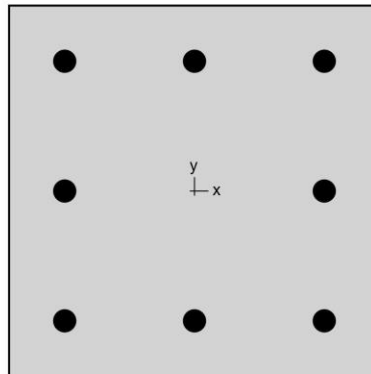

**StructurePoint**

Licensee stated below acknowledges that STRUCTUREPOINT (SP) is not and cannot be responsible for either the accuracy or adequacy of the material supplied as input for processing by the spColumn computer program. Furthermore, STRUCTUREPOINT neither makes any warranty expressed nor implied with respect to the correctness of the output prepared by the spColumn program. Although STRUCTUREPOINT has endeavored to produce spColumn error free the program is not and cannot be certified infallible. The final and only responsibility for analysis, design and engineering documents is the licensee's. Accordingly, STRUCTUREPOINT disclaims all responsibility in contract, negligence or other tort for any analysis, design or engineering documents prepared in connection with the use of the spColumn program. Licensed to: StructurePoint. License ID: 00000-0000000-4-1E2C3-1E2C3

## Contents

1. General Information .....	3
2. Material Properties .....	3
2.1. Concrete .....	3
2.2. Steel .....	3
3. Section .....	3
3.1. Shape and Properties .....	3
3.2. Section Figure .....	4
3.3. Exterior Points .....	4
4. Reinforcement .....	4
4.1. Bar Set: ASTM A615 .....	4
4.2. Confinement and Factors .....	4
4.3. Arrangement .....	5
4.4. Bars Provided .....	5
5. Factored Loads and Moments with Corresponding Capacity Ratios .....	5
6. Diagrams .....	6
6.1. PM at $\theta=26$ [deg] [User] .....	6
6.2. MM at P=484.1 [kip] [User] .....	7
6.3. MM at P=314.7 [kip] [User] .....	8

## List of Figures

Figure 1: Column section .....	4
--------------------------------	---

STRUCTUREPOINT - spColumn v6.50  
Licensed to: StructurePoint. License ID: 00000-0000000-4-1E2C3-1E2C3  
C:\ACI 318-14 Examples\Combined Axial Force and Biaxial Bending - Square Column.col

Page | 3  
4/15/2020  
3:07 PM

## 1. General Information

File Name	...Combined Axial Force and Biaxial Bending -...
Project	Square Column - Biaxial
Column	Corner
Engineer	SP
Code	ACI 318-14
Bar Set	ASTM A615
Units	English
Run Option	Investigation
Run Axis	Biaxial
Slenderness	Not Considered
Column Type	Structural
Capacity Method	Critical capacity

## 2. Material Properties

### 2.1. Concrete

Type	Standard
$f'_c$	4 ksi
$E_c$	3605 ksi
$f_c$	3.4 ksi
$\epsilon_u$	0.003 in/in
$\beta_1$	0.85

### 2.2. Steel

Type	Standard
$f_y$	60 ksi
$E_s$	29000 ksi
$\epsilon_{yt}$	0.00206897 in/in

## 3. Section

### 3.1. Shape and Properties

Type	Irregular
$A_g$	256 in <sup>2</sup>
$I_x$	5461.33 in <sup>4</sup>
$I_y$	5461.33 in <sup>4</sup>
$r_x$	4.6188 in
$r_y$	4.6188 in
$X_o$	0 in
$Y_o$	0 in



### 3.2. Section Figure

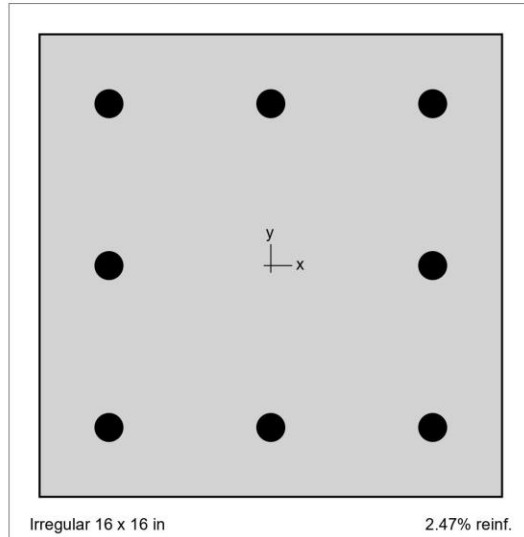

Figure 1: Column section

### 3.3. Exterior Points

Points	X in	Y in	Points	X in	Y in	Points	X in	Y in
1	-8.0	-8.0	2	8.0	-8.0	3	8.0	8.0
4	-8.0	8.0						

## 4. Reinforcement

### 4.1. Bar Set: ASTM A615

Bar	Diameter in	Area in <sup>2</sup>	Bar	Diameter in	Area in <sup>2</sup>	Bar	Diameter in	Area in <sup>2</sup>
#3	0.38	0.11	#4	0.50	0.20	#5	0.63	0.31
#6	0.75	0.44	#7	0.88	0.60	#8	1.00	0.79
#9	1.13	1.00	#10	1.27	1.27	#11	1.41	1.56
#14	1.69	2.25	#18	2.26	4.00			

### 4.2. Confinement and Factors

Confinement type	Tied
For #10 bars or less	#3 ties
For larger bars	#4 ties
<b>Capacity Reduction Factors</b>	
Axial compression, (a)	0.8
Tension controlled $\phi$ , (b)	0.9
Compression controlled $\phi$ , (c)	0.65

#### 4.3. Arrangement

Pattern	Irregular
Bar layout	---
Cover to	---
Clear cover	---
Bars	---
Total steel area, $A_s$	6.32 in <sup>2</sup>
Rho	2.47 %
Minimum clear spacing	4.60 in

#### 4.4. Bars Provided

Area in <sup>2</sup>	X in	Y in	Area in <sup>2</sup>	X in	Y in	Area in <sup>2</sup>	X in	Y in
0.79	-5.6	5.6	0.79	0.0	5.6	0.79	5.6	5.6
0.79	5.6	0.0	0.79	5.6	-5.6	0.79	0.0	-5.6
0.79	-5.6	-5.6	0.79	-5.6	0.0			

#### 5. Factored Loads and Moments with Corresponding Capacity Ratios

NOTE: Calculations are based on "Critical Capacity" Method.

No.	Demand			Capacity			Parameters at Capacity			Capacity Ratio
	$P_u$ kip	$M_{ux}$ k-ft	$M_{uy}$ k-ft	$\phi P_n$ kip	$\phi M_{nx}$ k-ft	$\phi M_{ny}$ k-ft	NA Depth in	$\epsilon_t$	$\phi$	
1	484.11	197.16	95.67	358.41	124.60	60.46	13.42	0.00116	0.650	1.54 #
2	314.68	128.15	62.19	314.68	128.15	62.19	12.64	0.00141	0.650	1.00 #

# Section capacity exceeded. Revise design!

Two factored loads are applied to locate the nominal (point 1) and design (point 2) capacities of the section. In both points, the capacity ratio is calculated based on the design capacity causing point 1 to show 54% beyond design capacity.

## 6. Diagrams

### 6.1. PM at $\theta=26$ [deg] [User]

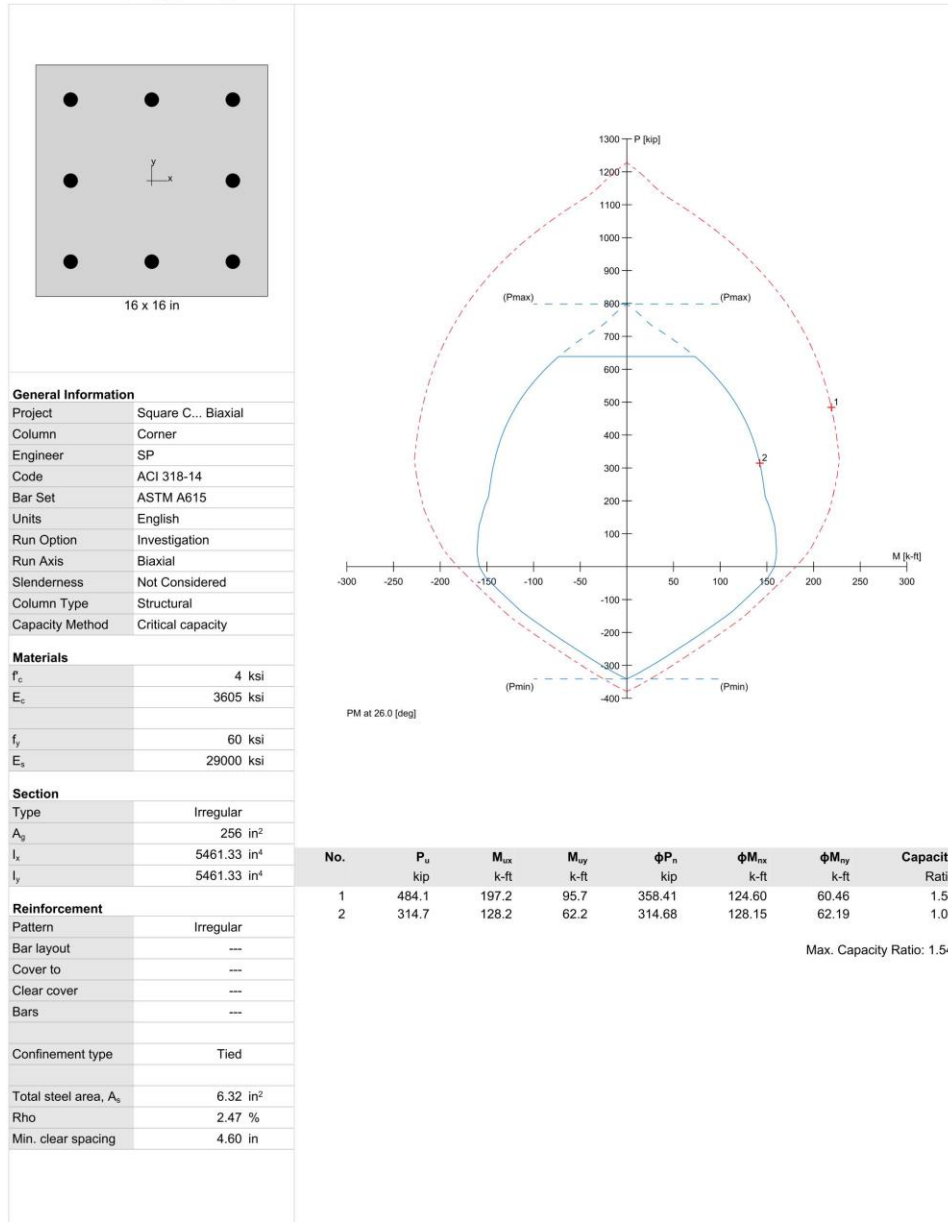

**6.2. MM at P=484.1 [kip] [User]**

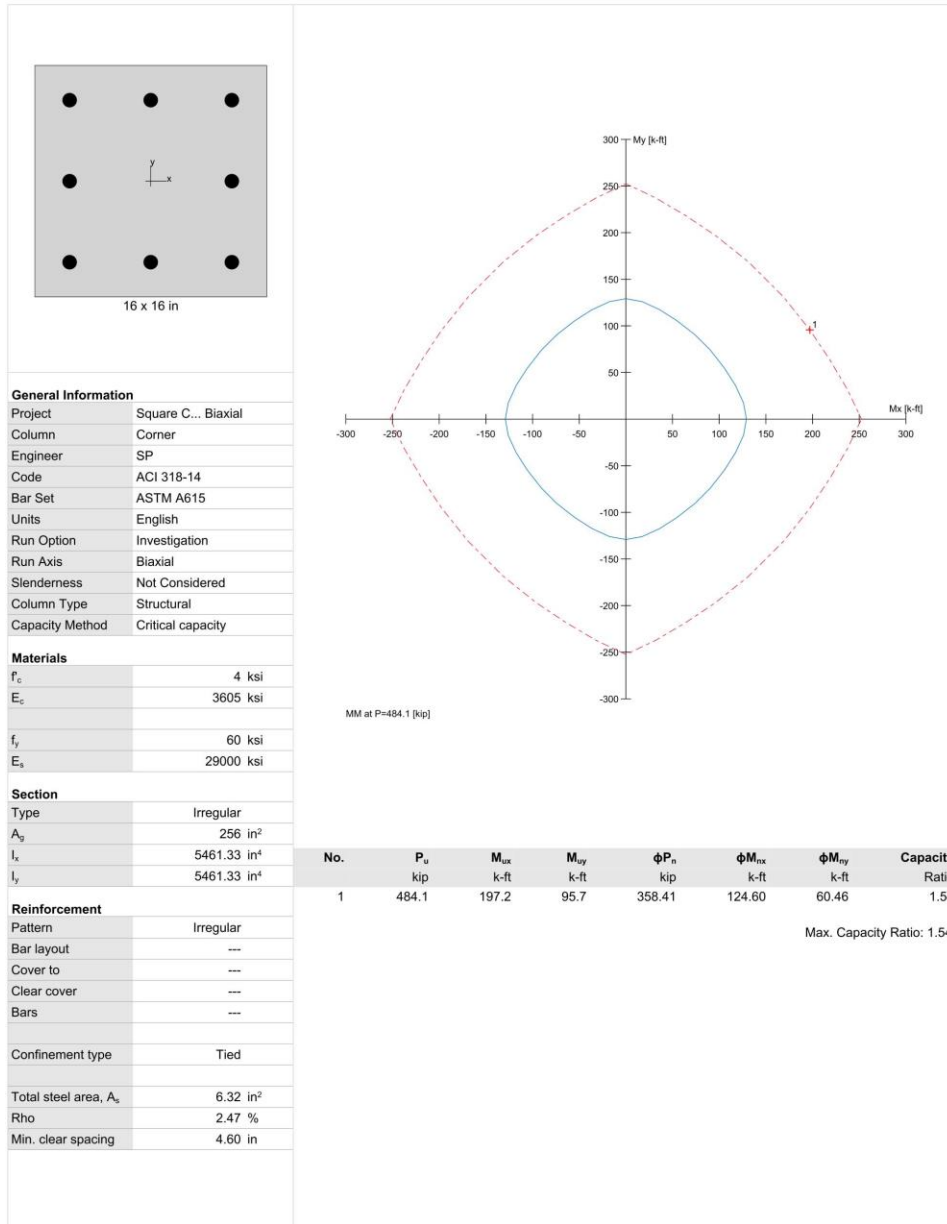

**6.3. MM at P=314.7 [kip] [User]**

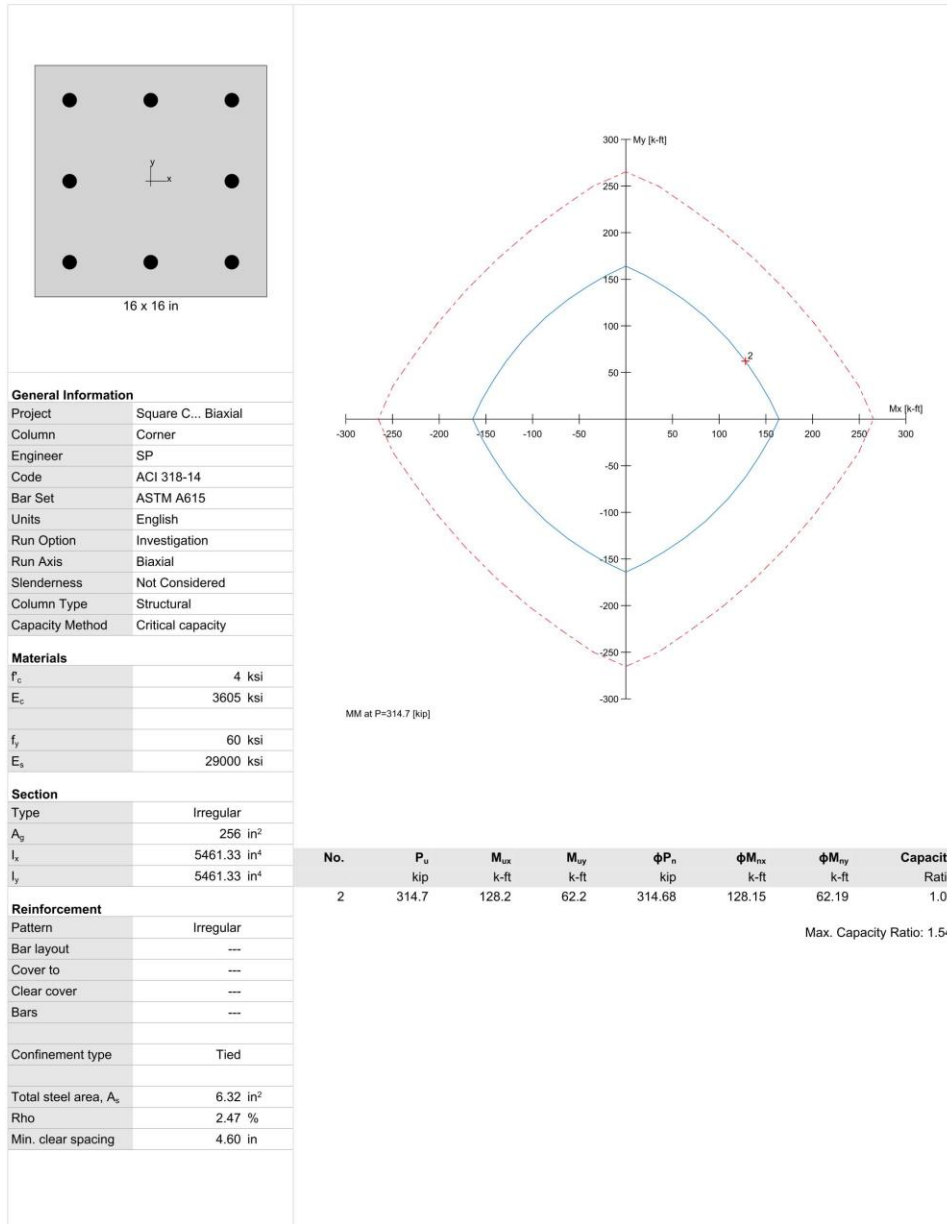

### 3. Summary and Comparison of Design Results

Table 2 - Comparison of Results			
Parameter	Reference	Hand	spColumn
c, in.	12.66	12.66	12.64
d <sub>s</sub> , in.	18.58	18.58	18.58
ε <sub>s5</sub> , in./in.	0.00140	0.00140	0.00141
φP <sub>n</sub> , kip	315.0	315.6	314.7
φM <sub>nx</sub> , kip-ft	128.3	128.1	128.2
φM <sub>ny</sub> , kip-ft	62.3	62.1	62.2

In all of the hand calculations and the reference used illustrated above, the results are in precise agreement with the automated exact results obtained from the [spColumn](#) program.

#### 4. Conclusions & Observations

The analysis of the reinforced concrete section performed by [spColumn](#) conforms to the provisions of the Strength Design Method and Unified Design Provisions with all conditions of strength satisfying the applicable conditions of equilibrium and strain compatibility.

In most building design calculations, such as the examples shown for flat plate or flat slab concrete floor systems, all building columns may be subjected to biaxial bending ( $M_x$  and  $M_y$ ) due to lateral effects and unbalanced moments from both directions of analysis. This requires an investigation of the column P- $M_x$ - $M_y$  interaction diagram in two directions simultaneously (axial force interaction with biaxial bending).

This example shows the calculations needed to obtain one point on the three-dimensional failure surface (biaxial  $M_x$ - $M_y$  interaction diagram). Generating the three-dimensional failure surface (interaction diagram) for a column section subjected to a combined axial force and biaxial bending moments is tedious and challenging for engineers and the use of a computer aid can save time and eliminate errors. StructurePoint's [spColumn](#) program can, quickly, simply and accurately generate the three-dimensional failure surface (interaction diagram) for all commonly encountered column, beam or wall sections in addition to highly complex and irregular cross-sections.

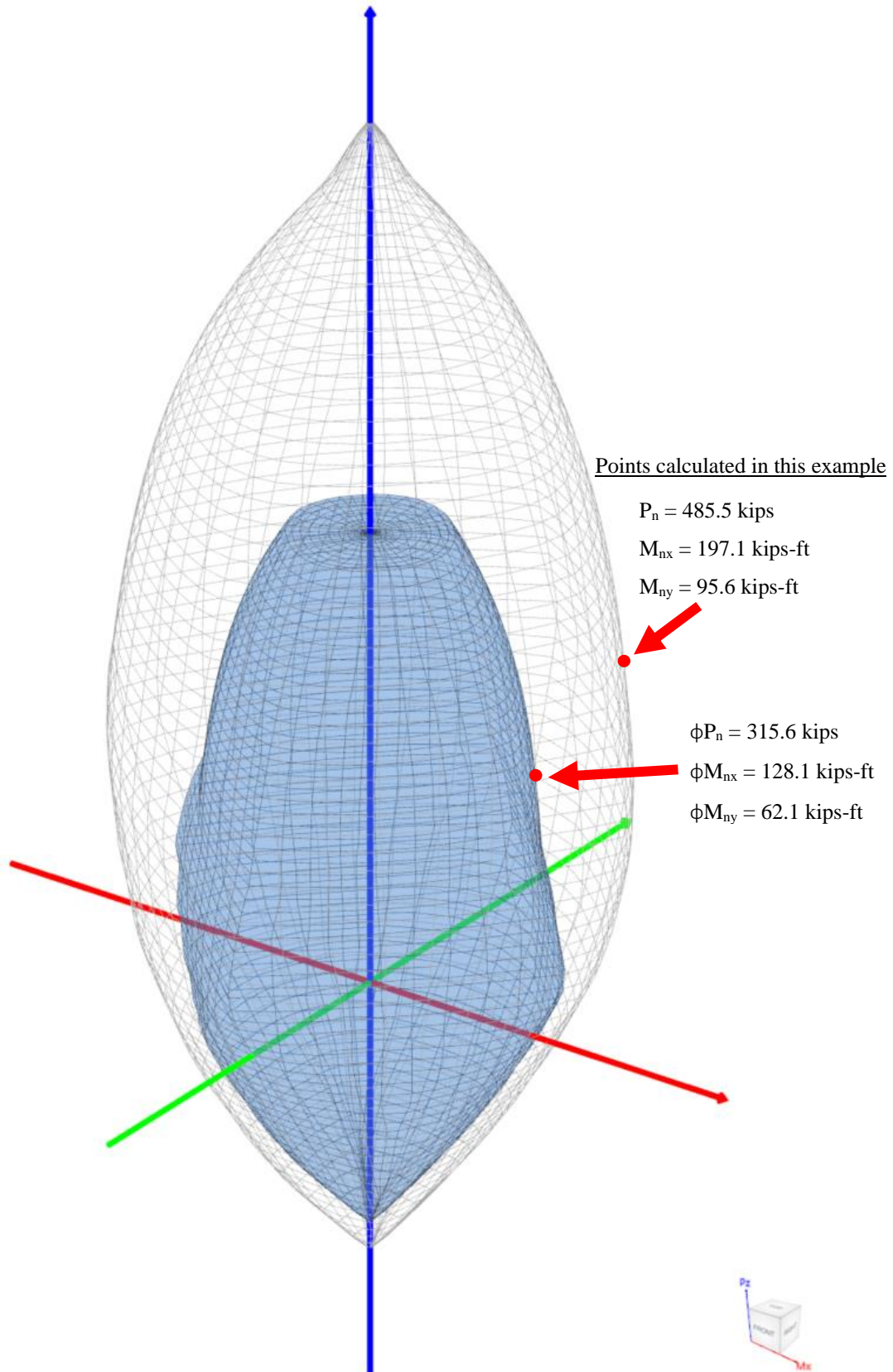

Figure 9 – Interaction Diagram in Two Directions (Biaxial) (spColumn)



The spColumn 2D/3D viewer is a powerful tool especially for investigating interaction diagrams (failure surfaces) for columns and walls sections subjected to a combined axial force and biaxial bending moments. The viewer allows the user to view and analyze 2D interaction diagrams and contours along with 3D failure surfaces in a multi viewport environment. The following figure shows three views of:

1. P-M interaction diagram cut at angle of  $26^\circ$
2. Mx-My interaction diagram cut at axial load of 314.7 kip in compression
3. A 3D failure surface (interaction diagram showing the points calculated in this example).

Figures (11-12) and (13) show 3D visualization of failure surface with a horizontal and vertical plane cut, respectively.

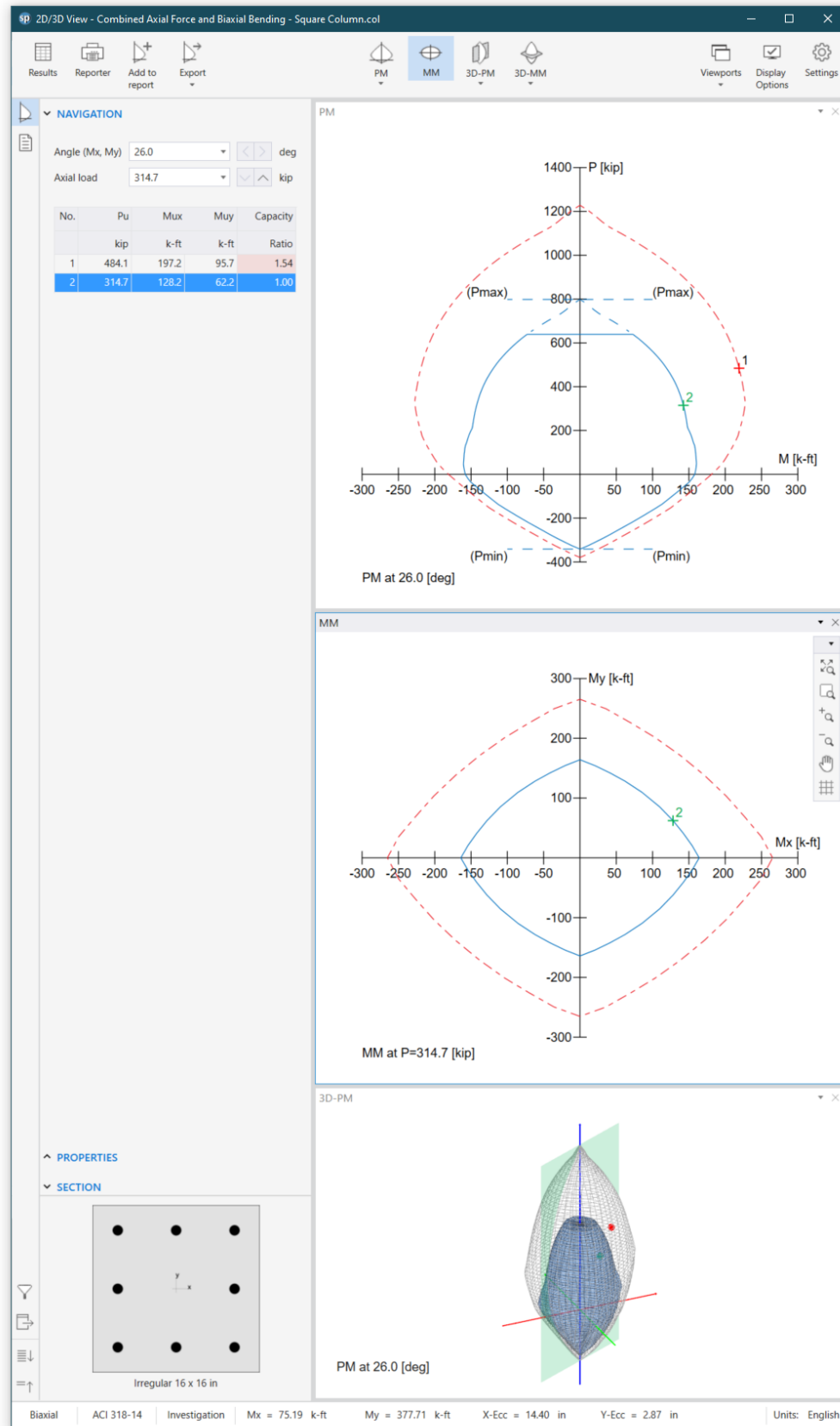

Figure 10 – 2D/3D Biaxial Interaction Diagram Viewer (spColumn)

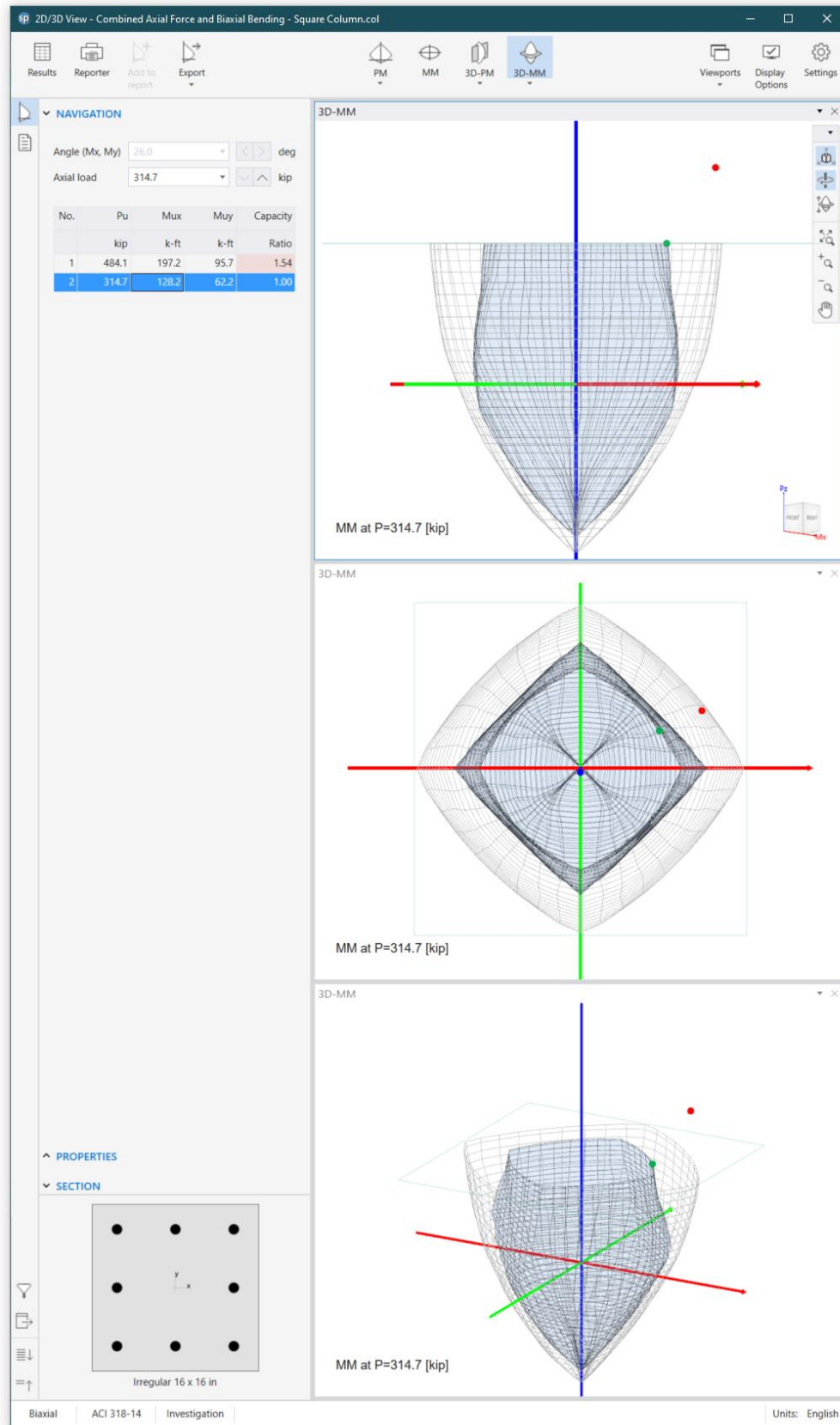

Figure 11 – 3D Visualization of Failure Surface with a Horizontal Plane Cut at P = 314.7 kip (spColumn)

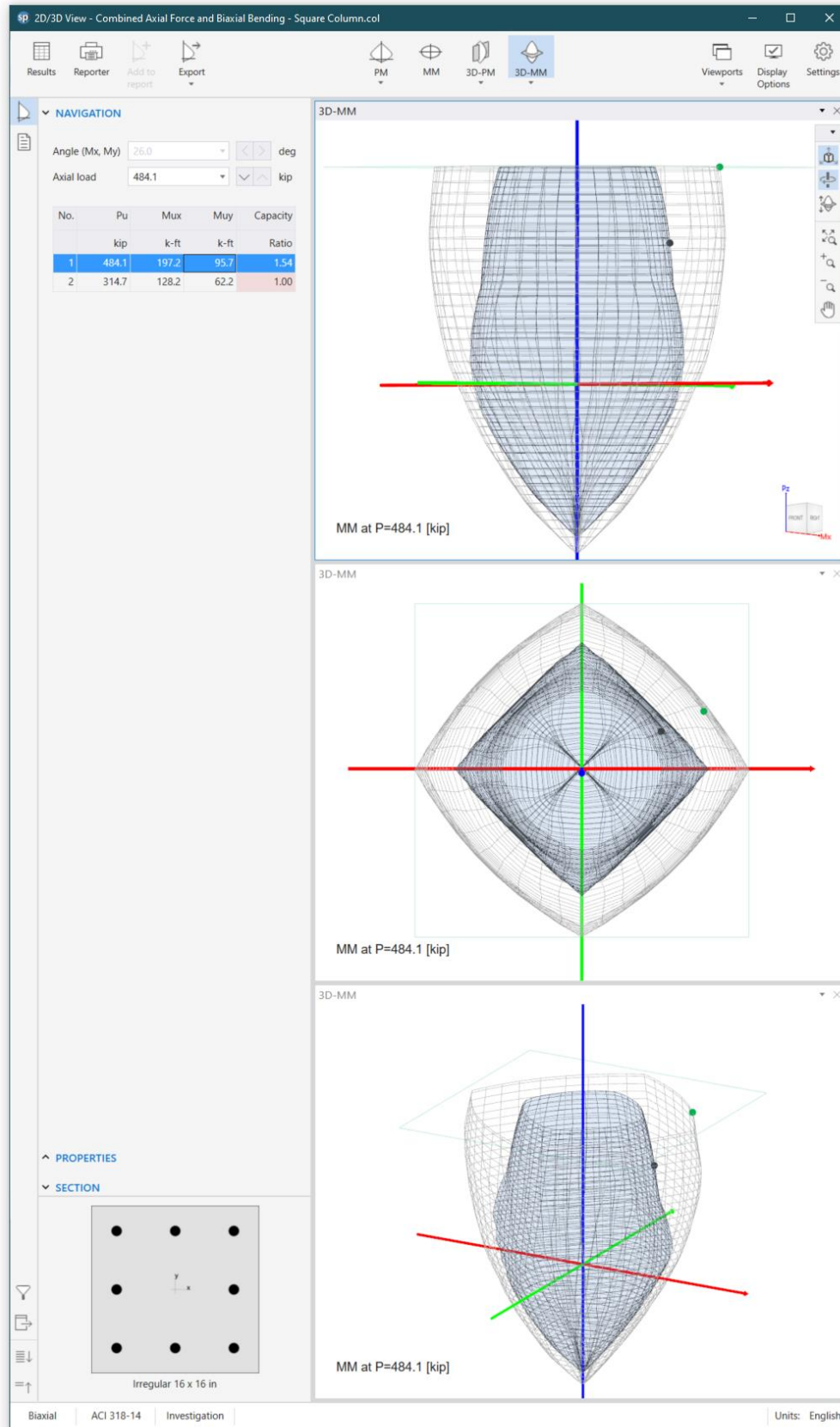

Figure 12 – 3D Visualization of Failure Surface with a Horizontal Plane Cut at P = 484.1 kip (spColumn)

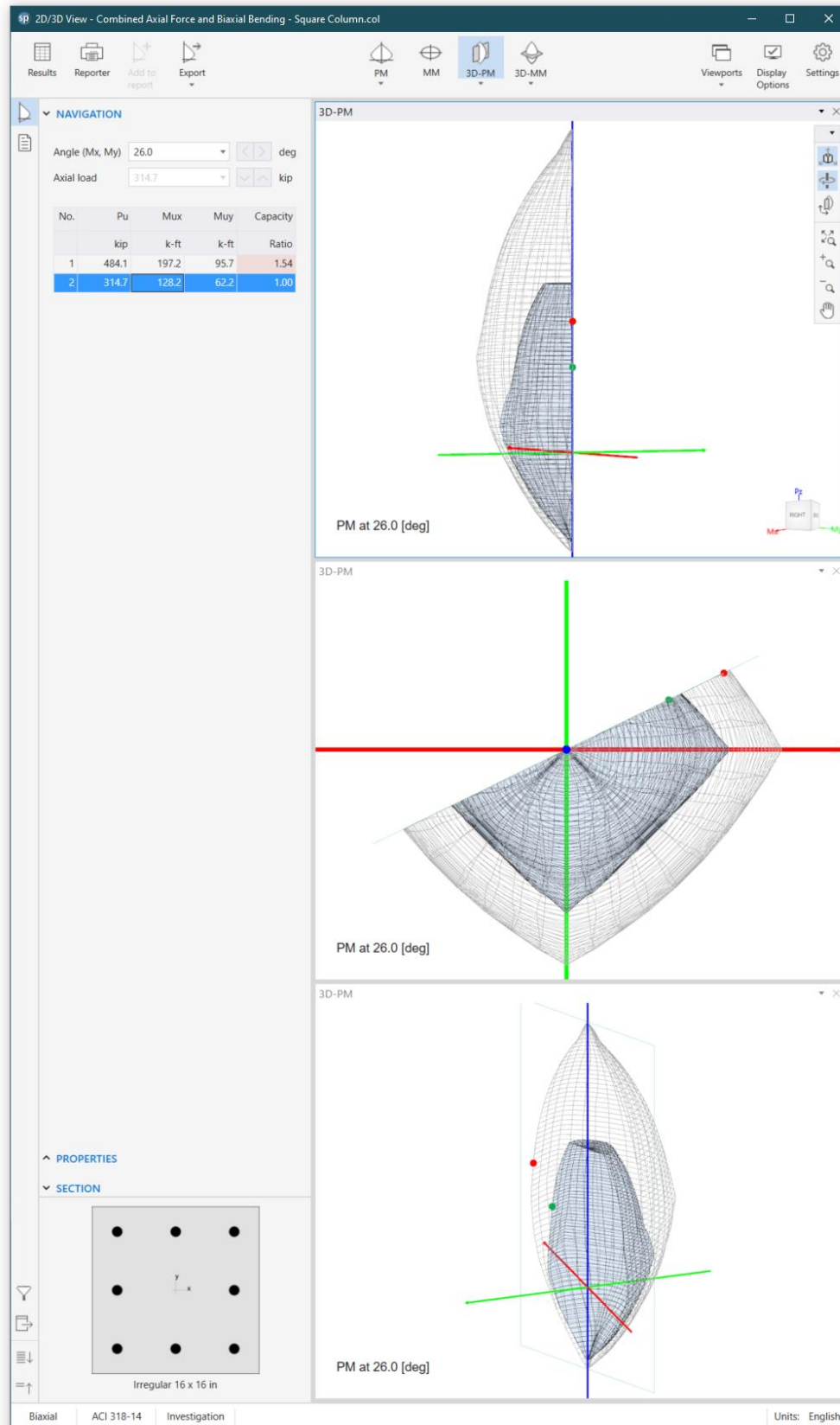

Figure 13 – 3D Visualization of Failure Surface with a Vertical Plane Cut at 26° (spColumn)